



北京
BEIJING
天津新港
TIANJIN PORT

0317-3041255 3599978 13700379811 13930774516



CANGZHOU HUAYE METAL PRODUCTS CO.,LTD.

Add: Xiwang New Industrial Zone, Mengcun County, Hebei Province, China.

Tel: 0086-317-3041255

Fax: 0086-317-3019121 3599978

Mobile: 13700379811

13930774516

E-mail: binghua@heinfo.net

hebeibinghua@yahoo.cn

HTTP://WWW.HUAYEFITTING.COM

MSN: HEBEIBINGHUA@HOTMAIL.COM



CANGZHOU
HUAYE

HUAYE 

CANGZHOU HUAYE

METAL PRODUCTS
CO.,LTD.

HUAYE Company Introduction

沧州华业金属制品有限公司始建于2004年，为专业生产碳钢焊接管件及法兰的中外合资企业。占地17000平方米，公司座落于“中国管件之都”河北省孟村县希望新区内。距天津港150公里，天津国际机场160公里，北京国际机场260公里，地理位置优越，交通便利。公司主要生产各种规格型号的美标、日标、德标弯头，三通，异径管，管帽及法兰等系列产品，年产量达10000吨。

公司自创建以来始终坚持以高起点，高标准为宗旨，以质取胜为原则，产品畅销全国各地并大量出口到东南亚、中东、南美、非洲、欧洲、北美等几十个国家和地区。

Established in 2004, Cangzhou Huaye Metal Products Co., Ltd as one of sino-singapore cooperated enterprise, specialized in manufacturing carbon steel butt-welded pipe fitting and carbon steel flanges.

Covers an area of 17000 square meter, and over 10000 tons annual output of carbon steel butt-welded pipe fitting and carbon steel flanges.

Our main products carbon steel butt-welded pipe fitting such as elbows, tees, reducers, bends and caps, etc as per ANSI B16.9 ASTM A234 WPB standard, and JIS 2311 and DIN 2605 etc standard. Carbon steel flanges contain forge steel and cast steel, conform to ANSI B16.5, BS, DIN, EN and JIS standards. We have established the quality management system conforming to ISO 9001, and have got the certificate of conformity of quality system certification.

As an entirely export-oriented pipe fittings and flanges manufacturer, We provide about 100% of the turnover for Europe and other countries such as southeast and middle east and have acquired good reputations among the clients all over the world. With excellent quality, provide the best quality and highly service is our purpose.

◎ CANGZHOU HUAYE METAL PRODUCTS CO., LTD. ◎



CANGZHOU HUAYE

METAL PRODUCTS CO., LTD.

CANGZHOU HUAYE QUALIFICATION PAPER >>



Open up market with perfect products win customers with honesty & sincerity.

CANGZHOU HUAYE
PRODUCTION EQUIPMENT

CANGZHOU HUAYE
PRODUCTION EQUIPMENT

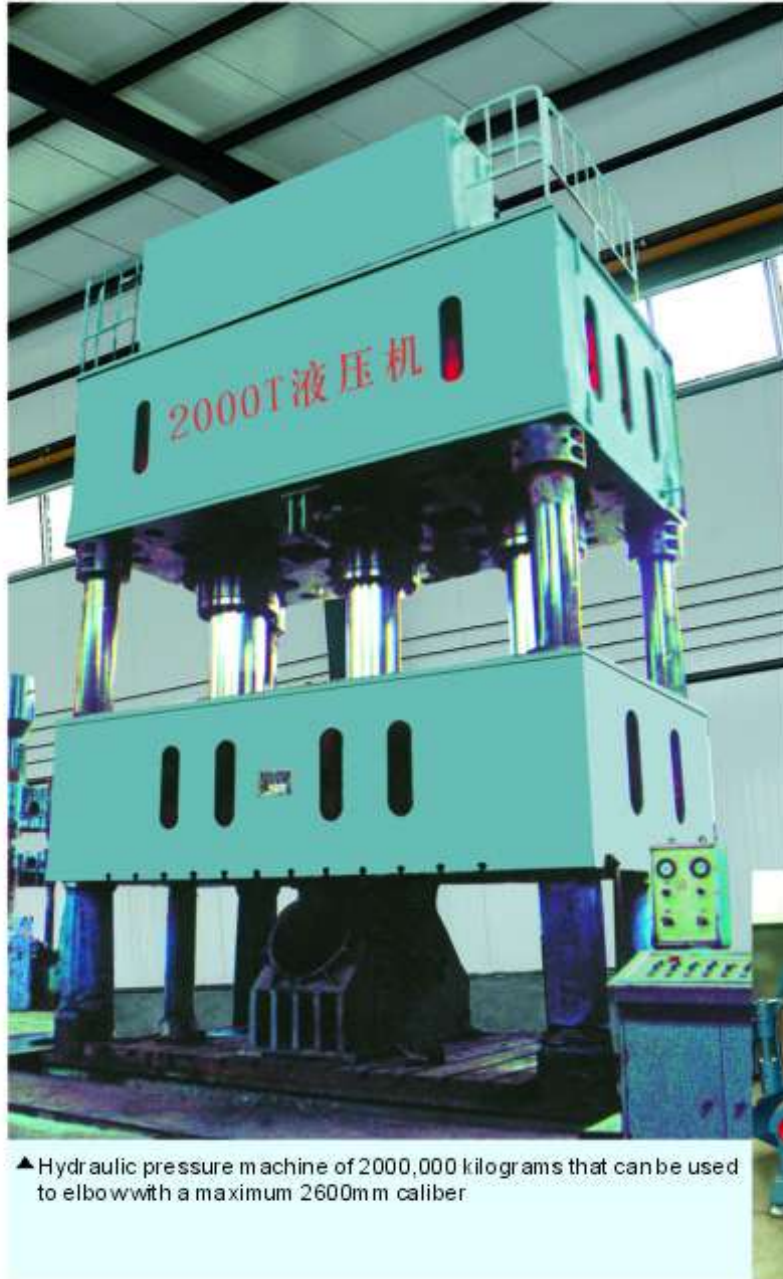

▲ Hydraulic pressure machine of 2000,000 kilograms that can be used to elbow with a maximum 2600mm caliber



▲ Annealing furnace



▲ Intermediate-frequency extruding machine



▲ Polishing machine



▲ Cutter



▲ Sloping-machine of high-pressure pipe fittings



▲ Bend simmering

CANGZHOU HUAYE
PRODUCTION EQUIPMENT



▲ Large vertical vehicle

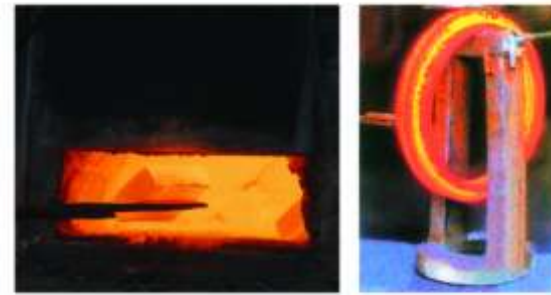

▲ air hammer



▲ Cutter

CANGZHOU HUAYE
DETECTING EQUIPMENT



▲ Physical and chemical testing



▲ tensile test



▲ Spectrum detecting



▲ Metallurgical analyzing



▲ Electronic spectrometer



▲ Ultrasonic detecting



▲ Thickness measurement



▲ X-ray detecting

CANGZHOU HUAYE
PRODUCTS SERIES >>



CANGZHOU HUAYE
PRODUCTS SERIES >>



CANGZHOU HUAYE
PIPE FITTING PRODUCTION PROCESS >>

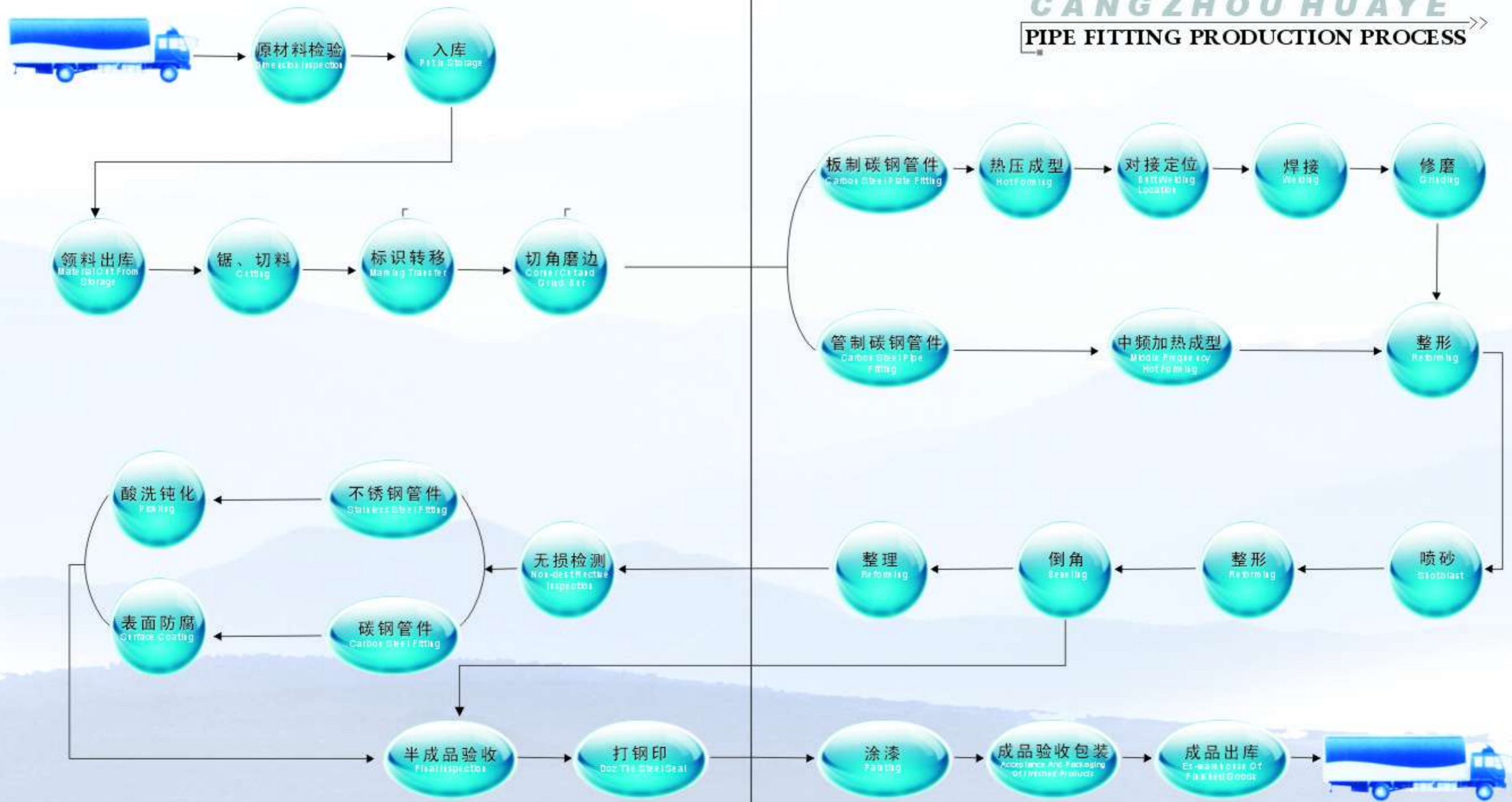

CANGZHOU HUAYE
APPLICATION AREA



APPLICATION :

Petrochemical industry/power/chemical industry/light industry/metallurgy/ship-building/urban construction.

Wall Thickness Schedules (ASME)

ASME B36.10 ASME B36.19

Nominal Pipe Size (NPS)		Outside Diameter		Nominal Wall Thickness									
A	B	MM	IN	Sch 5s		Sch 10s		Sch 40s		Sch 80s		Sch 160	
				MM	IN	MM	IN	MM	IN	MM	IN	MM	IN
8	1/4	13.7	0.540	-	-	1.85	0.085	2.24	0.088	3.02	0.119	-	-
10	3/8	17.1	0.675	-	-	1.85	0.085	2.31	0.091	3.20	0.126	-	-
15	1/2	21.3	0.840	1.65	0.065	2.11	0.083	2.77	0.109	3.73	0.147	1.65	0.065
20	3/4	26.7	1.05	1.65	0.065	2.11	0.083	2.87	0.113	3.91	0.154	1.65	0.065
25	1	33.4	1.32	1.65	0.065	2.77	0.109	3.38	0.133	4.55	0.179	1.65	0.065
32	1 1/4	42.2	1.66	1.65	0.065	2.77	0.109	3.56	0.140	4.85	0.191	1.65	0.065
40	1 1/2	48.3	1.9	1.65	0.065	2.77	0.109	3.68	0.145	5.08	0.200	1.65	0.065
50	2	60.3	2.38	1.65	0.065	2.77	0.109	3.91	0.154	5.54	0.218	1.65	0.065
65	2 1/2	73.0	2.88	2.11	0.083	3.05	0.120	5.16	0.203	7.01	0.276	2.11	0.083
80	3	88.9	3.5	2.11	0.083	3.05	0.120	5.49	0.218	7.62	0.300	2.11	0.083
90	3 1/2	101.6	4	2.11	0.083	3.05	0.120	5.74	0.226	8.08	0.318	2.11	0.083
100	4	114.3	4.5	2.11	0.083	3.05	0.120	6.02	0.237	8.56	0.337	2.11	0.083
125	5	141.3	5.56	2.77	0.109	3.40	0.134	6.55	0.258	9.53	0.375	2.77	0.109
150	6	168.3	6.62	2.77	0.109	3.40	0.134	7.11	0.280	10.97	0.432	2.77	0.109
200	8	219.1	8.62	2.77	0.109	3.76	0.148	8.18	0.322	12.70	0.500	2.77	0.109
250	10	273.0	10.75	3.40	0.134	4.19	0.165	9.27	0.365	12.70	0.500	3.40	0.134
300	12	323.8	12.75	3.96	0.156	4.57	0.180	9.53	0.375	12.70	0.500	3.96	0.156
350	14	355.6	14	3.96	0.156	4.78	0.188	9.53	0.375	12.70	0.500	3.96	0.156
400	16	406.4	16	4.19	0.165	4.78	0.188	9.53	0.375	12.70	0.500	4.19	0.165
450	18	457	18	4.19	0.165	4.78	0.188	9.53	0.375	12.70	0.500	4.19	0.165
500	20	508	20	4.78	0.188	5.54	0.218	9.53	0.375	12.70	0.500	4.78	0.188
550	22	559	22	4.78	0.188	5.54	0.218	9.53	0.375	12.70	0.500	4.78	0.188
600	24	610	24	5.54	0.218	6.35	0.250	9.53	0.375	12.70	0.500	5.54	0.218
650	26	660	26	-	-	-	-	-	-	-	-	-	-
700	28	711	28	-	-	-	-	-	-	-	-	-	-
750	30	762	30	6.35	0.250	7.92	0.312	9.53	0.375	12.70	0.500	6.35	0.250
800	32	813	32	-	-	-	-	-	-	-	-	-	-
850	34	864	34	-	-	-	-	-	-	-	-	-	-
900	36	914	36	-	-	-	-	-	-	-	-	-	-
950	38	965	38	-	-	-	-	-	-	-	-	-	-
1000	40	1016	40	-	-	-	-	-	-	-	-	-	-
1050	42	1067	42	-	-	-	-	-	-	-	-	-	-
1100	44	1118	44	-	-	-	-	-	-	-	-	-	-
1150	46	1168	46	-	-	-	-	-	-	-	-	-	-
1200	48	1219	48	-	-	-	-	-	-	-	-	-	-

Nominal Pipe Size (NPS)		Outside Diameter		Nominal wall Thickness									
A	B	MM	IN	Sch 10		Sch 20		Sch 30		STD		Sch 40	
				MM	IN	MM	IN	MM	IN	MM	IN	MM	IN
8	1/4	13.7	0.540	1.65	0.065	-	-	1.85	0.073	2.24	0.088	2.24	0.088
10	3/8	17.1	0.675	1.65	0.065	-	-	1.85	0.073	2.31	0.091	2.31	0.091
15	1/2	21.3	0.840	2.11	0.083	-	-	2.41	0.095	2.77	0.109	2.77	0.109
20	3/4	26.7	1.05	2.11	0.083	2.2	-	2.41	0.095	2.87	0.113	2.87	0.113
25	1	33.4	1.32	2.77	0.109	2.8	-	2.90	0.114	3.38	0.133	3.38	0.133
32	1 1/4	42.2	1.66	2.77	0.109	2.8	-	2.97	0.117	3.56	0.140	3.56	0.140
40	1 1/2	48.3	1.9	2.77	0.109	2.8	-	3.18	0.125	3.68	0.145	3.68	0.145
50	2	60.3	2.38	2.77	0.109	2.9	-	3.18	0.125	3.91	0.154	3.91	0.154
65	2 1/2	73.0	2.88	3.05	0.120	3.5	-	4.78	0.188	5.16	0.203	5.16	0.203
80	3	88.9	3.5	3.05	0.120	4.0	-	4.78	0.188	5.49	0.216	5.49	0.216
90	3 1/2	101.6	4	3.05	0.120	-	-	4.78	0.188	5.74	0.226	5.74	0.226
100	4	114.3	4.5	3.05	0.120	4.0	-	4.78	0.188	6.02	0.237	6.02	0.237
125	5	141.3	5.56	3.40	0.134	-	-	-	-	6.55	0.258	6.55	0.258
150	6	168.3	6.62	3.40	0.134	5.0	-	-	-	7.11	0.280	7.11	0.280
200	8	219.1	8.62	3.76	0.148	6.35	0.250	7.04	0.277	8.18	0.322	8.18	0.322
250	10	273.0	10.75	4.19	0.165	6.35	0.250	7.80	0.307	9.27	0.365	9.27	0.365
300	12	323.8	12.75	4.57	0.180	6.35	0.250	8.38	0.330	9.53	0.375	10.31	0.406
350	14	355.6	14	6.35	0.250	7.92	0.312	9.53	0.375	9.53	0.375	11.13	0.438
400	16	406.4	16	6.35	0.250	7.92	0.312	9.53	0.375	9.53	0.375	12.70	0.500
450	18	457	18	6.35	0.250	7.92	0.312	11.13	0.438	9.53	0.375	14.27	0.562
500	20	508	20	6.35	0.250	9.53	0.375	12.70	0.500	9.53	0.375	15.09	0.594
550	22	559	22	6.35	0.250	9.53	0.375	12.70	0.500	9.53	0.375	-	-
600	24	610	24	6.35	0.250	9.53	0.375	14.27	0.562	9.53	0.375	17.48	0.688
650	26	660	26	7.92	0.312	12.70	0.500	-	-	9.53	0.375	-	-
700	28	711	28	7.92	0.312	12.70	0.500	15.88	0.625	9.53	0.375	-	-
750	30	762	30	7.92	0.312	12.70	0.500	15.88	0.625	9.53	0.375	-	-
800	32	813	32	7.92	0.312	12.70	0.500	15.88	0.625	9.53	0.375	17.48	0.688
850	34	864	34	7.92	0.312	12.70	0.500	15.88	0.625	9.53	0.375	17.48	0.688
900	36	914	36	7.92	0.312	12.70	0.500	15.88	0.625	9.53	0.375	19.05	0.750
950	38	965	38	-	-	-	-	-	-	9.53	0.375	-	-
1000	40	1016	40	-	-	-	-	-	-	9.53	0.375	-	-
1050	42	1067	42	-	-	-	-	-	-	9.53	0.375	-	-
1100	44	1118	44	-	-	-	-	-	-	9.53	0.375	-	-
1150	46	1168	46	-	-	-	-	-	-	9.53	0.375	-	-
1200	48	1219	48	-	-	-	-	-	-	9.53	0.375	-	-

**Wrought Steel Buttwelding Fittings(ASME)
Long and Short Radius Elbows**

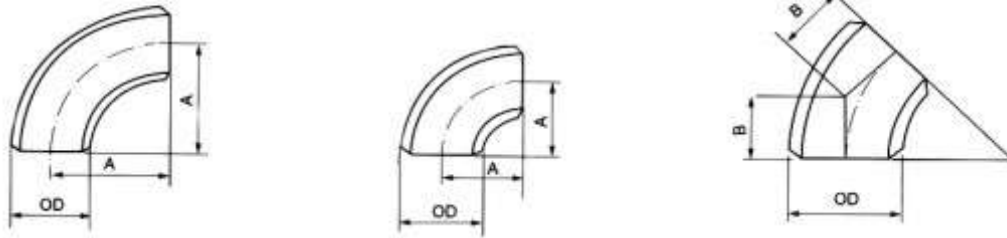

ASME B16.9, B16.28

Nominal pipe size(NPS)	Outside Diameter at bevel OD		Center-to-End							
			90° Elbows A				45° Elbows B			
			Long Radius		Short Radius		Long Radius		Short Radius	
			IN	MM	IN	MM	IN	MM	IN	MM
1/2	0.84	21.3	1.5	38	-	-	0.82	18	-	-
3/4	1.05	26.7	1.12	29	-	-	0.44	11	-	-
1	1.32	33.4	1.5	38	1	25	0.88	22	0.41	10
1 1/4	1.66	42.2	1.88	48	1.25	32	1	25	0.52	13
1 1/2	1.9	48.3	2.25	57	1.5	38	1.12	29	0.82	18
2	2.38	60.3	3	76	2	51	1.38	35	0.83	21
2 1/2	2.88	73.0	3.75	95	2.5	64	1.75	44	1.04	26
3	3.5	88.9	4.5	114	3	76	2	51	1.24	32
3 1/2	4	101.6	5.25	133	3.5	89	2.25	57	1.45	37
4	4.5	114.3	6	152	4	102	2.5	64	1.66	42
5	5.56	141.3	7.5	190	5	127	3.12	79	2.07	53
6	6.62	168.3	9	229	6	152	3.75	95	2.50	63
8	8.62	219.1	12	305	8	203	5	127	3.31	84
10	10.75	273.0	15	381	10	254	6.25	159	4.14	105
12	12.75	323.8	18	457	12	305	7.5	190	4.97	126
14	14	355.6	21	533	14	356	8.75	222	5.80	147
16	16	406.4	24	610	16	406	10	254	6.63	168
18	18	457	27	686	18	457	11.25	286	7.46	189
20	20	508	30	762	20	508	12.5	318	8.28	210
22	22	559	33	838	22	559	13.5	343	9.11	232
24	24	610	36	914	24	610	15	381	9.94	253
26	26	660	39	991	26	660	16	405	10.77	274
28	28	711	42	1067	28	711	17.25	438	11.60	295
30	30	762	45	1143	30	762	18.5	470	12.43	316
32	32	813	48	1219	32	813	19.75	502	14.89	378
34	34	864	51	1295	34	864	21	533	14.08	358
36	36	914	54	1372	36	914	22.25	565	14.91	379
38	38	965	57	1448	38	965	23.62	600	15.74	400
40	40	1016	60	1524	40	1016	24.88	632	16.57	421
42	42	1067	63	1600	42	1067	26	660	17.40	442
44	44	1118	66	1676	44	1118	27.38	695	18.23	463
46	46	1168	69	1753	46	1168	28.62	727	19.05	484
48	48	1219	72	1829	48	1219	29.88	759	19.88	505

**Wrought Steel Buttwelding Fittings(ASME)
Long and Short Radius Returns**

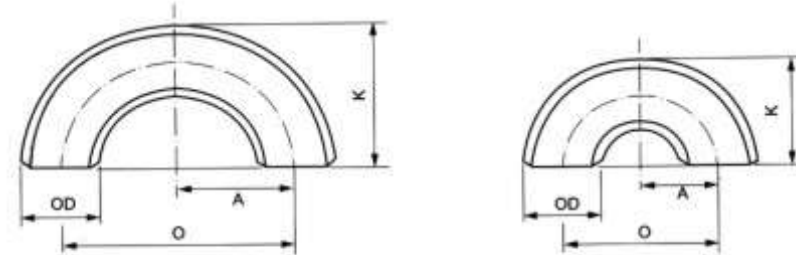

ASME B16.9, B16.28

Nominal pipe size(NPS)	Outside Diameter at bevel OD		Center-to-End				End-to-End			
			180 Returns O				180 Returns K			
			Long Radius		Short Radius		Long Radius		Short Radius	
			IN	MM	IN	MM	IN	MM	IN	MM
1/2	0.84	21.3	3	76	-	-	1.88	48	-	-
3/4	1.05	26.7	2.25	57	-	-	1.69	43	-	-
1	1.32	33.4	3	76	2	51	2.19	56	1.62	41
1 1/4	1.66	42.2	3.75	95	2.5	64	2.75	70	2.06	52
1 1/2	1.9	48.3	4.5	114	3	76	3.25	83	2.44	62
2	2.38	60.3	6	152	4	102	4.19	106	3.19	81
2 1/2	2.88	73.0	7.5	190	5	127	5.19	132	3.94	100
3	3.5	88.9	9	229	6	152	6.25	159	4.75	121
3 1/2	4	101.6	10.5	267	7	178	7.25	184	5.5	140
4	4.5	114.3	12	305	8	203	8.25	210	6.25	159
5	5.56	141.3	15	381	10	254	10.31	262	7.75	197
6	6.62	168.3	18	457	12	305	12.31	313	9.31	237
8	8.62	219.1	24	610	16	406	16.31	414	12.31	313
10	10.75	273.0	30	762	20	508	20.38	518	15.38	391
12	12.75	323.8	36	914	24	610	24.38	619	18.38	467
14	14	355.6	42	1067	28	711	28	711	21	533
16	16	406.4	48	1219	32	813	32	813	24	610
18	18	457	54	1372	36	914	36	914	27	686
20	20	508	60	1524	40	1016	40	1016	30	762
22	22	559	66	1676	44	1118	44	1118	33	838
24	24	610	72	1829	48	1219	48	1219	36	914

Wrought Steel Butt Welding Fittings (ASME)
Straight Tees and Caps

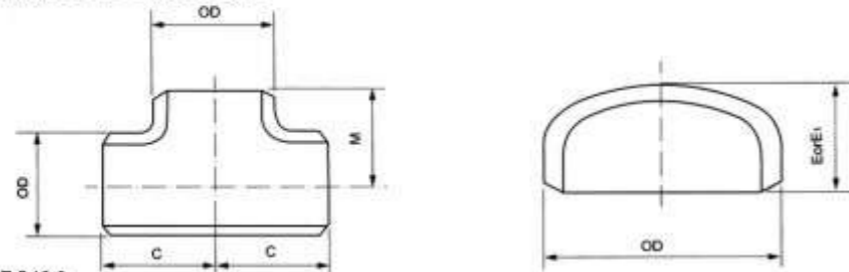

ASME B16.9

Nominal pipe size (NPS)	Outside Diameter at bevel OD		Center-to-End				End-to-End					
			Straight Tees				Caps					
			C		M(1)		Length(2)		Limiting Wall Thickness for Length E		Length(3)	
			IN	MM	IN	MM	IN	MM	IN	MM	IN	MM
1/2	0.84	21.3	1	25	1	25	1	25	0.18	4.57	1	25
3/4	1.05	26.7	1.12	29	1.12	29	1	25	0.15	3.81	1	25
1	1.32	33.4	1.5	38	1.5	38	1.5	38	0.18	4.57	1.5	38
1 1/4	1.66	42.2	1.88	48	1.88	48	1.5	38	0.19	4.83	1.5	38
1 1/2	1.9	48.3	2.25	57	2.25	57	1.5	38	0.2	5.08	1.5	38
2	2.38	60.3	2.5	64	2.5	64	1.5	38	0.22	5.59	1.75	44
2 1/2	2.88	73.0	3	76	3	76	1.5	38	0.28	7.11	2	51
3	3.5	88.9	3.38	86	3.38	86	2	51	0.3	7.62	2.5	64
3 1/2	4	101.6	3.75	95	3.75	95	2.5	64	0.32	8.13	3	76
4	4.5	114.3	4.12	105	4.12	105	2.5	64	0.34	8.64	3	76
5	5.56	141.3	4.88	124	4.88	124	3	76	0.38	9.65	3.5	89
6	6.62	168.3	5.62	143	5.62	143	3.5	89	0.43	10.92	4	102
8	8.62	219.1	7	178	7	178	4	102	0.5	12.7	5	127
10	10.75	273.0	8.5	216	8.5	216	5	127	0.5	12.7	6	152
12	12.75	323.8	10	254	10	254	6	152	0.5	12.7	7	178
14	14	355.6	11	279	11	279	6.5	165	0.5	12.7	7.5	191
16	16	406.4	12	305	12	305	7	178	0.5	12.7	8	203
18	18	457.2	13.5	343	13.5	343	8	203	0.5	12.7	9	229
20	20	508	15	381	15	381	9	229	0.5	12.7	10	254
22	22	558.8	16.5	419	16.5	419	10	254	0.5	12.7	10	254
24	24	609.6	17	432	17	432	10.5	267	0.5	12.7	12	305
26	26	660.4	19.5	495	19.5	495	10.5	267	-	-	-	-
28	28	711.2	20.2	521	20.2	521	10.5	267	-	-	-	-
30	30	762	22	559	22	559	10.5	267	-	-	-	-
32	32	812.8	23.5	597	23.5	597	10.5	267	-	-	-	-
34	34	863.6	25	635	25	635	10.5	267	-	-	-	-
36	36	914.4	26.5	673	26.5	673	10.5	267	-	-	-	-
38	38	965.2	28	711	28	711	12	305	-	-	-	-
40	40	1016	29.5	749	29.5	749	12	305	-	-	-	-
42	42	1066.8	30	762	28	711	12	305	-	-	-	-
44	44	1117.6	32	813	30	762	13.5	343	-	-	-	-
46	46	1168.4	33.5	851	31.5	800	13.5	343	-	-	-	-
48	48	1219.2	35	889	33	838	13.5	343	-	-	-	-

- NOTES:
 (1) outlet dimension M for NPS 26 and larger is recommended but not required.
 (2) length E applies for thickness not exceeding that given in column " Limiting Wall Thickness for Length E"
 (3) length E1 applies for thickness greater than that given in column " Limiting Wall Thickness for Length E " for NPS24 and smaller.

Wrought Steel Butt Welding Fittings (ASME)
Lap Joint Stub Ends

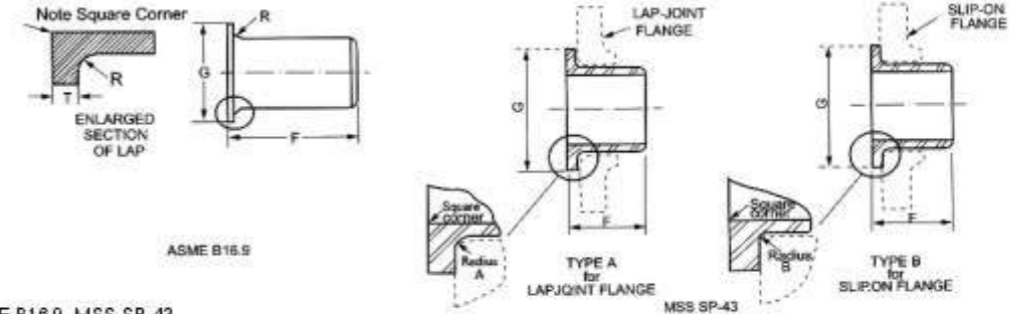

ASME B16.9, MSS SP-43

Nominal pipe size (NPS)	Outside Diameter at bevel OD		Outside Diameter of barrel				Diameter of Lap G (Nominal & Max)	
			Max		Min			
			IN	MM	IN	MM		
1/2	0.84	21.3	0.896	22.8	0.809	20.5	1.38	35
3/4	1.05	26.7	1.106	28.1	1.019	25.9	1.69	43
1	1.32	33.4	1.376	35	1.284	32.6	2	51
1 1/4	1.66	42.2	1.716	43.6	1.629	41.4	2.5	64
1 1/2	1.9	48.3	1.965	49.9	1.869	47.5	2.88	73
2	2.38	60.3	2.456	62.4	2.344	59.5	3.62	92
2 1/2	2.88	73.0	2.966	75.3	2.844	72.2	4.12	106
3	3.5	88.9	3.596	91.3	3.469	88.1	5	127
3 1/2	4	101.6	4.096	104	3.969	100.8	5.5	140
4	4.5	114.3	4.593	116.7	4.469	113.5	6.19	157
5	5.56	141.3	5.683	144.3	5.532	140.5	7.31	185
6	6.62	168.3	6.743	171.3	6.594	167.5	8.5	218
8	8.62	219.1	8.743	222.1	8.594	218.3	10.62	270
10	10.75	273.0	10.913	277.2	10.719	272.3	12.75	324
12	12.75	323.8	12.913	328	12.719	323.1	15	381
14	14	355.6	14.17	359.9	13.969	354.8	16.25	413
16	16	406.4	16.18	411	15.969	405.8	18.5	470
18	18	457	18.19	462	17.969	456	21	533
20	20	508	20.24	514	19.969	507	23	584
22	22	559	22.24	565	21.969	558	25.25	641
24	24	610	24.24	616	23.969	609	27.25	692

Nominal pipe size (NPS)	Length F				Radius R			
	ASME Long		ASME Short & MSS		MSS Type A & ASME (Nominal & Max)		MSS Type B (Max)	
	IN	MM	IN	MM	IN	MM	IN	MM
1/2	3	76	2	51	0.12	3	0.03	0.8
3/4	3	76	2	51	0.12	3	0.03	0.8
1	4	102	2	51	0.12	3	0.03	0.8
1 1/4	4	102	2	51	0.19	5	0.03	0.8
1 1/2	4	102	2	51	0.25	6	0.03	0.8
2	6	152	2.5	64	0.31	8	0.03	0.8
2 1/2	6	152	2.5	64	0.31	8	0.03	0.8
3	6	152	2.5	64	0.38	10	0.03	0.8
3 1/2	6	152	3	76	0.38	10	0.03	0.8
4	6	152	3	76	0.44	11	0.03	0.8
5	8	203	3	76	0.44	11	0.06	1.5
6	8	203	3.5	89	0.5	13	0.06	1.5
8	8	203	4	102	0.5	13	0.06	1.5
10	10	254	5	127	0.5	13	0.06	1.5
12	10	254	6	152	0.5	13	0.06	1.5
14	12	305	6	152	0.5	13	0.06	1.5
16	12	305	6	152	0.5	13	0.06	1.5
18	12	305	6	152	0.5	13	0.06	1.5
20	12	305	6	152	0.5	13	0.06	1.5
22	12	305	6	152	0.5	13	0.06	1.5
24	12	305	6	152	0.5	13	0.06	1.5

**Wrought Steel Buttwelding Fittings(ASME)
Reducing Tees and Concentric & Eccentric Reducers**

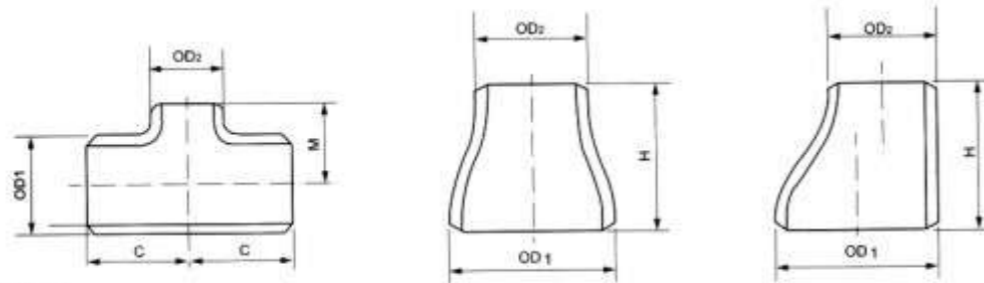

ASME B16.9

Nominal pipe size (NPS)	Outside Diameter at Bevel				Center-to-End				End-to-End	
	OD1		OD2		C		M		H	
	IN	MM	IN	MM	IN	MM	IN	MM	IN	MM
1/2 x 1/2	1.05	26.7	0.84	21.3	1.12	29	1.12	29	1.5	38
1 x 1/2	1.32	33.4	0.84	21.3	1.5	38	1.5	38	2	51
1 x 1	1.32	33.4	0.84	21.3	1.5	38	1.5	38	2	51
1 1/2 x 1	1.66	42.2	1.32	33.4	1.88	48	1.88	48	2	51
1 1/2 x 1/2	1.66	42.2	1.05	26.7	1.88	48	1.88	48	2	51
1 1/2 x 1 1/4	1.66	42.2	0.84	21.3	1.88	48	1.88	48	2	51
1 1/2 x 1 1/2	1.9	48.3	1.66	42.2	2.25	57	2.25	57	2.5	64
1 1/2 x 2	1.9	48.3	1.32	33.4	2.25	57	2.25	57	2.5	64
1 1/2 x 2 1/2	1.9	48.3	1.05	26.7	2.25	57	2.25	57	2.5	64
1 1/2 x 3	1.9	48.3	0.84	21.3	2.25	57	2.25	57	2.5	64
2 x 1 1/2	2.38	60.3	1.9	48.3	2.5	64	2.38	60	3	76
2 x 1 1/4	2.38	60.3	1.66	42.2	2.5	64	2.25	57	3	76
2 x 1	2.38	60.3	1.32	33.4	2.5	64	2	51	3	76
2 x 3/4	2.38	60.3	1.05	26.7	2.5	64	1.75	44	3	76
2 x 1/2	2.38	60.3	0.84	21.3	2.5	64	-	-	3	76
2 1/2 x 2	2.88	73	2.38	60.3	3	76	2.75	70	3.5	89
2 1/2 x 1 1/2	2.88	73	1.9	48.3	3	76	2.62	67	3.5	89
2 1/2 x 1 1/4	2.88	73	1.66	42.2	3	76	2.5	64	3.5	89
2 1/2 x 1	2.88	73	1.32	33.4	3	76	2.25	57	3.5	89
2 1/2 x 3/4	2.88	73	1.05	26.7	3	76	-	-	3.5	89
2 1/2 x 1/2	2.88	73	0.84	21.3	3	76	-	-	3.5	89
3 x 2 1/2	3.5	88.9	2.88	73	3.38	86	3.25	83	3.5	89
3 x 2	3.5	88.9	2.38	60.3	3.38	86	3	76	3.5	89
3 x 1 1/2	3.5	88.9	1.9	48.3	3.38	86	2.88	73	3.5	89
3 x 1 1/4	3.5	88.9	1.66	42.2	3.38	86	2.75	70	3.5	89
3 x 1	3.5	88.9	1.32	33.4	3.38	86	-	-	3.5	89
3 x 3/4	3.5	88.9	1.05	26.7	3.38	86	-	-	3.5	89
3 x 1/2	3.5	88.9	0.84	21.3	3.38	86	-	-	3.5	89
3 1/2 x 3	4	101.6	3.5	88.9	3.75	95	3.62	92	4	102
3 1/2 x 2 1/2	4	101.6	2.88	73	3.75	95	3.5	89	4	102
3 1/2 x 2	4	101.6	2.38	60.3	3.75	95	3.25	83	4	102
3 1/2 x 1 1/2	4	101.6	1.9	48.3	3.75	95	3.12	79	4	102
3 1/2 x 1 1/4	4	101.6	1.66	42.2	3.75	95	-	-	4	102
4 x 3 1/2	4.5	114.3	4	101.6	4.12	105	4	102	4	102
4 x 3	4.5	114.3	3.5	88.9	4.12	105	3.88	98	4	102
4 x 2 1/2	4.5	114.3	2.88	73	4.12	105	3.75	95	4	102
4 x 2	4.5	114.3	2.38	60.3	4.12	105	3.5	89	4	102
4 x 1 1/2	4.5	114.3	1.9	48.3	4.12	105	3.38	86	4	102
4 x 1 1/4	4.5	114.3	1.66	42.2	4.12	105	-	-	4	102
4 x 1	4.5	114.3	1.32	33.4	4.12	105	-	-	4	102

**Wrought Steel Buttwelding Fittings(ASME)
Reducing Tees and Concentric & Eccentric Reducers**

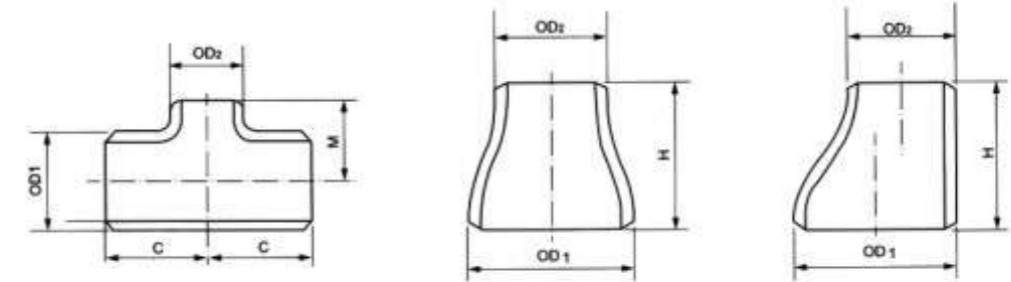

ASME B16.9

Nominal pipe size (NPS)	Outside Diameter at Bevel				Center-to-End				End-to-End	
	OD1		OD2		C		M(1)		H	
	IN	MM	IN	MM	IN	MM	IN	MM	IN	MM
5 x 4	5.56	141.3	4.5	114.3	4.88	124	4.62	117	5	127
5 x 3 1/2	5.56	141.3	4	101.6	4.88	124	4.5	114	5	127
5 x 3	5.56	141.3	3.5	88.9	4.88	124	4.38	111	5	127
5 x 2 1/2	5.56	141.3	2.88	73	4.88	124	4.25	108	5	127
5 x 2	5.56	141.3	2.38	60.3	4.88	124	4.12	105	5	127
5 x 1 1/2	5.56	141.3	1.9	48.3	4.88	124	*	*	5	127
5 x 1 1/4	5.56	141.3	1.66	42.2	4.88	124	*	*	5	127
6 x 5	6.62	168.3	4.56	114.3	5.62	143	5.38	137	5.5	140
6 x 4	6.62	168.3	4.5	114.3	5.62	143	5.12	130	5.5	140
6 x 3 1/2	6.62	168.3	4	101.6	5.62	143	5	127	5.5	140
6 x 3	6.62	168.3	3.5	88.9	5.62	143	4.88	124	5.5	140
6 x 2 1/2	6.62	168.3	2.88	73	5.62	143	4.75	121	5.5	140
6 x 2	6.62	168.3	2.38	60.3	5.62	143	*	*	5.5	140
8 x 6	8.62	219.1	6.62	168.3	7	178	6.62	168	6	152
8 x 5	8.62	219.1	5.56	141.3	7	178	6.38	162	6	152
8 x 4	8.62	219.1	4.5	114.3	7	178	6.12	156	6	152
8 x 3 1/2	8.62	219.1	4	101.6	7	178	6	152	6	152
8 x 3	8.62	219.1	3.5	88.9	7	178	*	*	6	152
10 x 8	10.75	273	8.62	219.1	8.5	216	8	203	7	178
10 x 6	10.75	273	6.62	168.3	8.5	216	7.62	194	7	178
10 x 5	10.75	273	5.56	141.3	8.5	216	7.5	191	7	178
10 x 4	10.75	273	4.5	114.3	8.5	216	7.25	184	7	178
10 x 3	10.75	273	3.5	88.9	8.5	216	*	*	7	178
12 x 10	12.75	323.8	10.75	273	10	254	9.5	241	8	203
12 x 8	12.75	323.8	8.62	219.1	10	254	9	229	8	203
12 x 6	12.75	323.8	6.62	168.3	10	254	8.62	219	8	203
12 x 5	12.75	323.8	5.56	141.3	10	254	8.5	216	8	203
12 x 4	12.75	323.8	4.5	114.3	10	254	*	*	8	203
14 x 12	14	355.6	12.75	323.8	11	279	10.62	270	13	330
14 x 10	14	355.6	10.75	273	11	279	10.12	257	13	330
14 x 8	14	355.6	8.62	219.1	11	279	9.75	248	13	330
14 x 6	14	355.6	6.62	168.3	11	279	9.38	238	13	330
14 x 5	14	355.6	5.56	141.3	11	279	*	*	13	330
16 x 14	16	406.4	14	355.6	12	305	12	305	14	356
16 x 12	16	406.4	12.75	323.8	12	305	11.62	295	14	356
16 x 10	16	406.4	10.75	273	12	305	11.12	283	14	356
16 x 8	16	406.4	8.62	219.1	12	305	10.75	273	14	356
16 x 6	16	406.4	6.62	168.3	12	305	10.38	264	14	356
18 x 16	18	457	16	406.4	13.5	343	13	330	15	381

NOTE:

(1) Outlet dimensions M for run sizes NPS 14 and larger is recommended but not required.

Wrought Steel Buttwelding Fittings(ASME)
Reducing Tees and Concentric & Eccentric Reducers

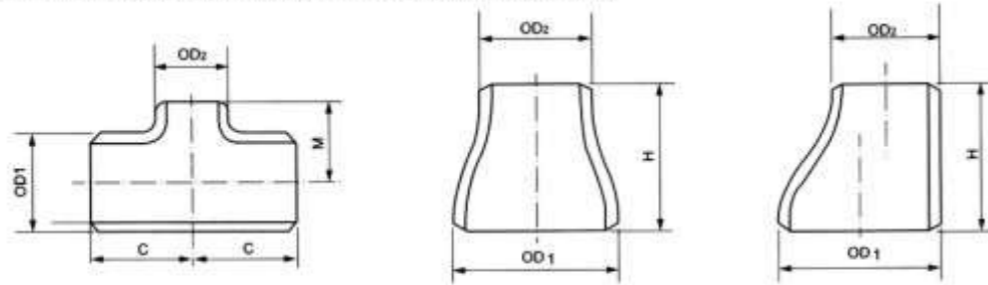

ASME B16.9

Nominal pipe size (NPS)	Outside Diameter at Bevel				Center-to-End				End-to-End	
	OD1		OD2		C		M(1)		H	
	IN	MM	IN	MM	IN	MM	IN	MM	IN	MM
18×14	18	457	14	355.6	13.5	343	13	330	15	381
18×12	18	457	12.75	323.8	13.5	343	12.62	321	15	381
18×10	18	457	10.75	273	13.5	343	12.12	308	15	381
18×8	18	457	8.62	219.1	13.5	343	11.75	298	15	381
20×18	20	508	18	457.2	15	381	14.5	368	20	508
20×16	20	508	16	406.4	15	381	14	356	20	508
20×14	20	508	14	355.6	15	381	14	356	20	508
20×12	20	508	12.75	323.8	15	381	13.62	346	20	508
20×10	20	508	10.75	273	15	381	13.12	333	20	508
20×8	20	508	8.62	219.1	15	381	12.75	324	20	508
22×20	22	559	20	508	16.5	419	16	406	20	508
22×18	22	559	18	457.2	16.5	419	15.5	394	20	508
22×16	22	559	16	406.4	16.5	419	15	381	20	508
22×14	22	559	14	355.6	16.5	419	15	381	20	508
22×12	22	559	12.75	323.8	16.5	419	14.62	371	20	508
22×10	22	559	10.75	273	16.5	419	14.12	359	20	508
24×22	24	610	22	558.8	17	432	17	432	20	508
24×20	24	610	20	508	17	432	17	432	20	508
24×18	24	610	18	457.2	17	432	16.5	419	20	508
24×16	24	610	16	406.4	17	432	16	406	20	508
24×14	24	610	14	355.6	17	432	16	406	20	508
24×12	24	610	12.75	323.8	17	432	15.62	397	20	508
24×10	24	610	10.75	273	17	432	15.12	384	20	508
26×24	26	660	24	609.6	19.5	495	19	483	24	610
26×22	26	660	22	558.6	19.5	495	18.5	470	24	610
26×20	26	660	20	508	19.5	495	18	457	24	610
26×18	26	660	18	457.2	19.5	495	17.5	444	24	610
26×16	26	660	16	406.4	19.5	495	17	432	24	610
26×14	26	660	14	355.6	19.5	495	17	432	24	610
26×12	26	660	12.75	323.8	19.5	495	16.62	422	24	610
28×26	28	711	26	660.4	20.5	52	20.5	521	24	610
28×24	28	711	24	609.6	20.5	152	20	508	24	610
28×22	28	711	22	558.8	20.5	152	19.5	495	24	610
28×20	28	711	20	508	20.5	1521	19	483	24	610
28×18	28	711	18	457.2	20.5	521	18.5	470	24	610
28×16	28	711	16	406.4	20.5	521	18	457	24	610
28×14	28	711	14	355.6	20.5	521	18	457	24	610
28×12	28	711	12.75	323.8	20.5	521	17.62	448	24	610
30×28	30	762	28	711.2	22	559	21.5	546	24	610

NOTE:
 (1) Outlet dimensions M for run sizes NPS 14 and larger is recommended but not required.

Wrought Steel Buttwelding Fittings(ASME)
Reducing Tees and Concentric & Eccentric Reducers

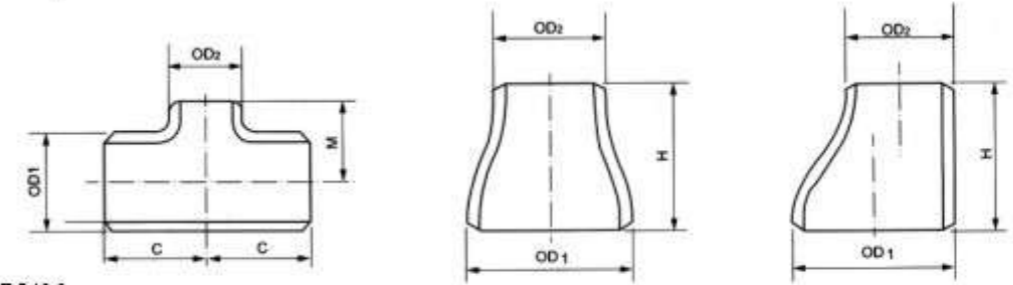

ASME B16.9

Nominal pipe size (NPS)	Outside Diameter at Bevel				Center-to-End				End-to-End	
	OD1		OD2		C		M(1)		H	
	IN	MM	IN	MM	IN	MM	IN	MM	IN	MM
30×26	30	762	26	660.4	22	559	21.5	546	24	610
30×24	30	762	24	609.6	22	559	21	533	24	610
30×22	30	762	22	558.8	22	559	20.5	521	24	610
30×20	30	762	20	508	22	559	20	508	24	610
30×18	30	762	18	457.2	22	559	19.5	495	24	610
30×16	30	762	16	406.4	22	559	19	483	24	610
30×14	30	762	14	355.6	22	559	19	483	24	610
30×12	30	762	12.75	323.8	22	559	18.62	473	24	610
30×10	30	762	10.75	273	22	559	18.12	460	24	610
32×30	32	813	30	762	23.5	597	23	584	24	610
32×28	32	813	28	711.2	23.5	597	22.5	572	24	610
32×26	32	813	26	660.4	23.5	597	22.5	572	24	610
32×24	32	813	24	609.6	23.5	597	22	559	24	610
32×22	32	813	22	558.8	23.5	597	21.5	546	24	610
32×20	32	813	20	508	23.5	597	21	533	24	610
32×18	32	813	18	457.2	23.5	597	20.5	521	24	610
32×16	32	813	16	406.4	23.5	597	20	508	24	610
32×14	32	813	14	355.6	23.5	597	20	508	24	610
34×32	34	864	32	812.8	25	635	24.5	622	24	610
34×30	34	864	30	762	25	635	24	610	24	610
34×28	34	864	28	711.2	25	635	23.5	597	24	610
34×26	34	864	26	660.4	25	635	23.5	597	24	610
34×24	34	864	24	609.6	25	635	23	584	24	610
34×22	34	864	22	558.8	25	635	22.5	572	24	610
34×20	34	864	20	508	25	635	22	559	24	610
34×18	34	864	18	457.2	25	635	21.5	546	24	610
34×16	34	864	16	406.4	25	635	21	533	24	610
36×34	36	914	34	863.6	26.5	673	26	660	24	610
36×32	36	914	32	812.8	26.5	673	25.5	648	24	610
36×30	36	914	30	762	26.5	673	25	635	24	610
36×28	36	914	28	711.2	26.5	673	24.5	622	24	610
36×26	36	914	26	660.4	26.5	673	24.5	622	24	610
36×24	36	914	24	609.6	26.5	673	24	610	24	610
36×22	36	914	22	558.8	26.5	673	23.5	597	24	610
36×20	36	914	20	508	26.5	673	23	584	24	610
36×18	36	914	18	457.2	26.5	673	22.5	572	24	610
36×16	36	914	16	406.4	26.5	673	22	559	24	610
38×36	38	965	36	914.4	28	711	28	711	24	610
38×34	38	965	34	863.6	28	711	27.5	698	24	610

NOTE:
 (1) Outlet dimensions M for run sizes NPS 14 and larger is recommended but not required.

**Wrought Steel Buttwelding Fittings(ASME)
Reducing Tees and Concentric & Eccentric Reducers**

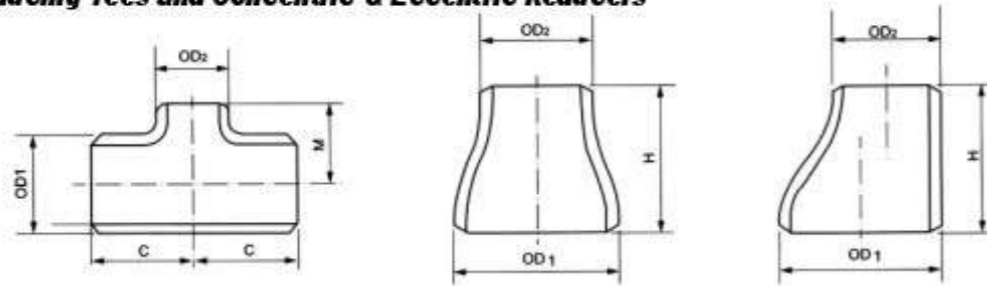

ASME B 16.9

Nominal pipe size(NPS)	Outside Diameter at Bevel				Center-to-End				End-to-End	
	OD1		OD2		C		M(1)		H	
	IN	MM	IN	MM	IN	MM	IN	MM	IN	MM
38×32	38	965	32	812.8	28	711	27	686	24	610
38×30	38	965	30	762	28	711	26.5	673	24	610
38×28	38	965	28	711.2	28	711	25.5	648	24	610
38×26	38	965	26	660.4	28	711	25.5	648	24	610
38×24	38	965	24	609.6	28	711	25	635	24	610
38×22	38	965	22	558.8	28	711	24.5	622	24	610
38×20	38	965	20	508	28	711	24	610	24	610
38×18	38	965	18	457.2	28	711	23.5	597	24	610
40×38	40	1016	38	965.2	29.5	749	29.5	749	24	610
40×36	40	1016	36	914.4	29.5	749	29	737	24	610
40×34	40	1016	34	863.6	29.5	749	28.5	724	24	610
40×32	40	1016	32	812.8	29.5	749	28	711	24	610
40×30	40	1016	30	762	29.5	749	27.5	698	24	610
40×28	40	1016	28	711.2	29.5	749	26.5	673	24	610
40×26	40	1016	26	660.4	29.5	749	26.5	673	24	610
40×24	40	1016	24	609.6	29.5	749	26	660	24	610
40×22	40	1016	22	558.8	29.5	749	25.5	648	24	610
40×20	40	1016	20	508	29.5	749	25	635	24	610
40×18	40	1016	18	457.2	29.5	749	24.5	622	24	610
42×40	42	1067	40	1016	30	762	28	711	24	610
42×38	42	1067	38	965.2	30	762	28	711	24	610
42×36	42	1067	36	914.4	30	762	28	711	24	610
42×34	42	1067	34	863.6	30	762	28	711	24	610
42×32	42	1067	32	812.8	30	762	28	711	24	610
42×30	42	1067	30	762	30	762	28	711	24	610
42×28	42	1067	28	711.2	30	762	27.5	698	24	610
42×26	42	1067	26	660.4	30	762	27.5	698	24	610
42×24	42	1067	24	609.6	30	762	26	660	24	610
42×22	42	1067	22	558.8	30	762	26	660	24	610
42×20	42	1067	20	508	30	762	26	660	24	610
42×18	42	1067	18	457.2	30	762	25.5	648	24	610
42×16	42	1067	16	406.4	30	762	25	635	24	610
44×42	44	1118	42	1066.8	32	813	30	762	24	610
44×40	44	1118	40	1016	32	813	29.5	749	24	610
44×38	44	1118	38	965.2	32	813	29	737	24	610
44×36	44	1118	36	914.4	32	813	28.5	724	24	610
44×34	44	1118	34	863.6	32	813	28.5	724	24	610
44×32	44	1118	32	812.8	32	813	28	711	24	610
44×30	44	1118	30	762	32	813	28	711	24	610

NOTE:

(1) Outlet dimensions M for run sizes NPS 14 and larger is recommended but not required.

**Wrought Steel Buttwelding Fittings(ASME)
Reducing Tees and Concentric & Eccentric Reducers**

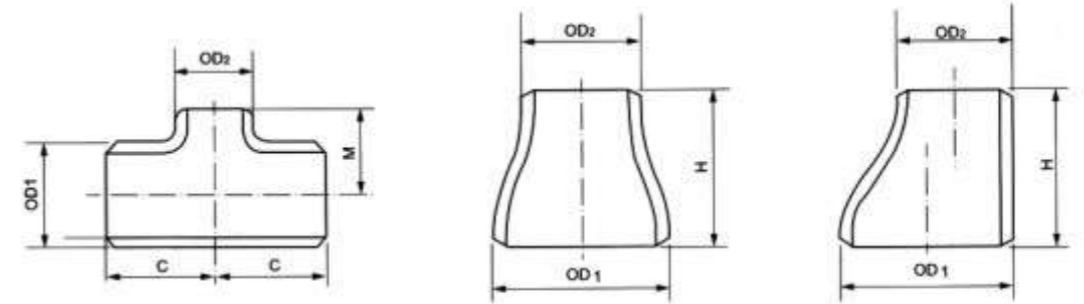

ASME B 16.9

Nominal pipe size(NPS)	Outside Diameter at Bevel				Center-to-End				End-to-End	
	OD1		OD2		C		M(1)		H	
	IN	MM	IN	MM	IN	MM	IN	MM	IN	MM
44×28	44	1118	28	711.2	32	813	27.5	698	24	610
44×26	44	1118	26	660.4	32	813	27.5	698	24	610
44×24	44	1118	24	609.6	32	813	27.5	698	24	610
44×22	44	1118	22	558.8	32	813	27	686	24	610
44×20	44	1118	20	508	32	813	27	686	24	610
46×44	46	1168	44	1117.6	33.5	851	31.5	800	28	711
46×42	46	1168	42	1066.8	33.5	851	31	787	28	711
46×40	46	1168	40	1016	33.5	851	30.5	775	28	711
46×38	46	1168	38	965.2	33.5	851	30	762	28	711
46×36	46	1168	36	914.4	33.5	851	30	762	28	711
46×34	46	1168	34	863.6	33.5	851	29.5	749	28	711
46×32	46	1168	32	812.8	33.5	851	29.5	749	28	711
46×30	46	1168	30	762	33.5	851	29	737	28	711
46×28	46	1168	28	711.2	33.5	851	29	737	28	711
46×26	46	1168	26	660.4	33.5	851	29	737	28	711
46×24	46	1168	24	609.6	33.5	851	28.5	724	28	711
46×22	46	1168	22	558.8	33.5	851	28.5	724	28	711
48×46	48	1219	46	1168.4	35	889	33	838	28	711
48×44	48	1219	44	1117.6	35	889	33	838	28	711
48×42	48	1219	42	1066.8	35	889	32	813	28	711
48×40	48	1219	40	1016	35	889	32	813	28	711
48×38	48	1219	38	965.2	35	889	32	813	28	711
48×36	48	1219	36	914.4	35	889	31	787	28	711
48×34	48	1219	34	863.6	35	889	31	787	28	711
48×32	48	1219	32	812.8	35	889	31	787	28	711
48×30	48	1219	30	762	35	889	30	762	28	711
48×28	48	1219	28	711.2	35	889	30	762	28	711
48×26	48	1219	26	660.4	35	889	30	762	28	711
48×24	48	1219	24	609.6	35	889	29	737	28	711
48×22	48	1219	22	558.8	35	889	29	737	28	711

NOTE:

(1) Outlet dimensions M for run sizes NPS 14 and larger is recommended but not required.

Steel Butt-Welding Pipe Fittings(JIS)
90° & 45° Elbows

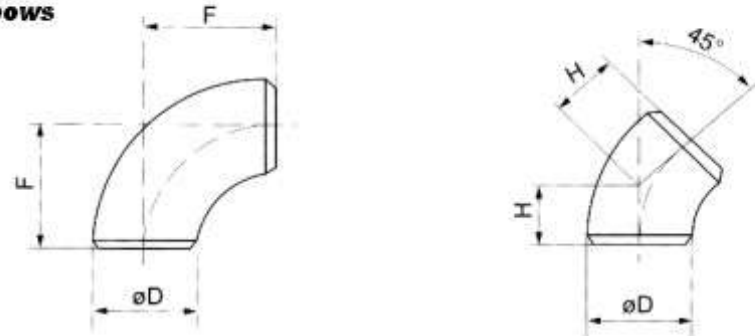

JIS B2311

Unit:mm

Nominal pipe size(NPS)		Outside Diameter D	Center-to-End		Center-to-End	
A	B		90° Elbows(F)		45° Elbows(H)	
			Long	Short	Long	Short*
15	1/2	21.7	38.1	-	15.8	-
20	3/4	27.2	38.1	-	15.8	-
25	1	34.0	38.1	25.4	15.8	10.5
32	1 1/2	42.7	47.6	31.8	19.7	13.2
40	1 1/2	48.6	57.2	38.1	23.7	15.8
50	2	60.5	76.2	50.8	31.6	21.0
65	2 1/2	76.3	95.3	63.5	39.5	26.3
80	3	89.1	114.3	76.2	47.3	31.6
90	3 1/2	101.6	133.4	88.9	55.3	36.8
100	4	114.3	152.4	101.6	63.1	42.1
125	5	139.8	190.5	127.0	78.9	52.6
150	6	165.2	228.6	152.4	94.7	63.1
200	8	216.3	304.8	203.2	126.3	84.2
250	10	267.4	381.0	254.0	157.8	105.2
300	12	318.5	457.2	304.8	189.4	126.3
350	14	355.6	533.4	355.6	220.9	147.3
400	16	406.4	609.6	406.4	252.5	168.4
450	18	457.2	685.8	457.2	284.1	189.4
500	20	508.0	762.0	508.0	315.6	210.4
550	22	558.8	838.2	558.8	347.2	231.5
600	24	609.6	914.4	609.6	378.7	252.5
650	26	660.4	990.6	660.4	410.3	273.6
700	28	711.2	1066.8	711.2	441.9	294.6
750	30	762.0	1143.0	762.0	473.4	315.7
800	32	812.8	1219.2	812.8	505.0	336.7
850	34	863.6	1295.4	863.6	536.6	357.7
900	36	914.4	1371.6	914.4	568.1	378.8
950	38	965.2	1447.8	965.2	599.7	399.8
1000	40	1016.0	1524.0	1016.0	631.2	420.9
1050	42	1066.8	1600.2	1066.8	662.8	441.9
1100	44	1117.6	1676.4	1117.6	694.4	463.0
1150	46	1168.4	1752.6	1168.4	725.9	484.0
2000	48	1219.2	1828.8	1219.2	757.5	505.1

Steel Butt-Welding Pipe Fittings(JIS)
180° Elbows, Caps, & Tees

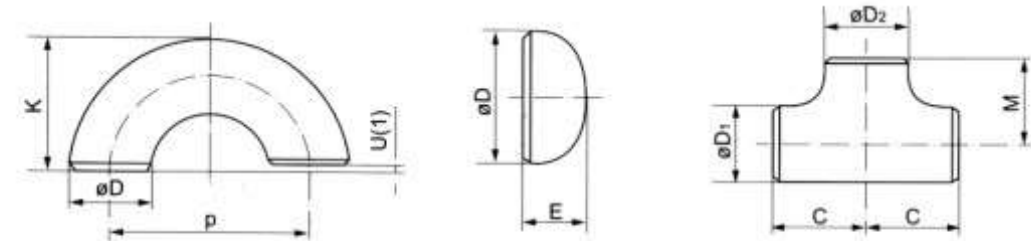

JIS B2311

Unit:mm

Nominal pipe size(NPS)		Outside Diameter D	Center to Center		End-to-End			Center-to-End	
A	B		180° Elbows(P)		180° Elbows(K)		Caps	Tees	
			Long	Short	Long	Short	E(2)	C	M
15	1/2	21.7	76.2	-	49.0	-	25.4	25.4	25.4
20	1/4	27.2	76.2	-	51.7	-	25.4	28.6	28.6
25	1	34.0	76.2	50.8	55.1	42.4	38.1	38.1	38.1
32	1 1/2	42.7	95.2	63.6	69.0	53.2	38.1	47.6	47.6
40	1 1/2	48.6	114.4	76.2	81.5	62.4	38.1	57.2	57.2
50	2	60.5	152.4	101.6	106.5	81.1	38.1	63.5	63.5
65	2 1/2	76.3	190.6	127.0	133.5	101.7	38.1	76.2	76.2
80	3	89.1	228.6	152.4	158.9	120.8	50.8	85.7	85.7
90	3 1/2	101.6	266.8	177.8	184.2	139.7	63.5	95.3	95.3
100	4	114.3	304.8	203.2	209.6	158.8	63.5	104.8	104.8
125	5	139.8	381.0	254.0	260.4	196.9	76.2	123.8	123.8
150	6	165.2	457.2	304.8	311.2	235.0	88.9	142.9	142.9
200	8	216.3	609.6	406.4	413.0	311.4	101.6	177.8	177.8
250	10	267.4	762.0	508.0	514.7	387.7	127.0	215.9	215.9
300	12	318.5	914.4	609.6	616.5	464.1	152.4	254.0	254.0
350	14	355.6	1066.8	711.2	711.2	533.4	165.1	279.4	279.4
400	16	406.4	1219.2	812.8	812.8	609.6	177.8	304.8	304.8
450	18	457.2	1371.6	914.4	914.4	685.8	203.2	342.9	342.9
500	20	508.0	1524.0	1016.0	1016.0	762.0	228.6	381.0	381.0
550	22	558.8	-	-	-	-	-	419.1	419.1
600	24	609.6	-	-	-	-	-	431.8	431.8
650	26	660.4	-	-	-	-	-	495.3	495.3
700	28	711.2	-	-	-	-	-	520.7	520.7
750	30	762.0	-	-	-	-	-	558.8	558.8
800	32	812.8	-	-	-	-	-	596.9	596.9
850	34	863.6	-	-	-	-	-	635.0	635.0
900	36	914.4	-	-	-	-	-	673.1	673.1
950	38	965.2	-	-	-	-	-	711.2	711.2
1000	40	1016.0	-	-	-	-	-	749.3	749.3
1050	42	1066.8	-	-	-	-	-	762.0	711.2
1100	44	1117.6	-	-	-	-	-	812.8	762.0
1150	46	1168.4	-	-	-	-	-	850.9	800.1
1200	48	1219.2	-	-	-	-	-	889.0	838.2

NOTE:

- (1) For alignment of the end faces U see the table on page 38.
- (2) Only SGP is applicable to the dimension E.

Steel Butt-Welding Pipe Fittings(JIS)
Lap Joint Stub Ends

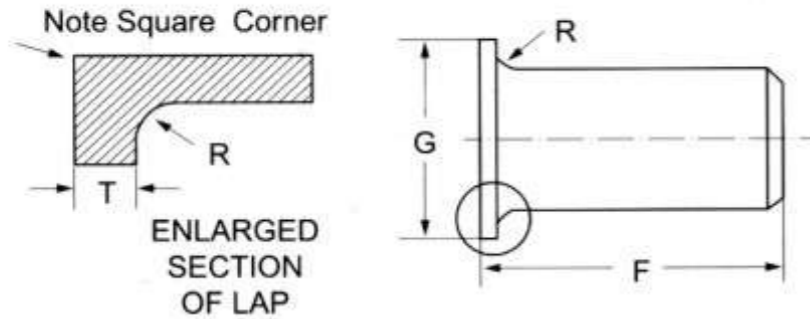

JIS B2220
JPI-7S-15

Unit:mm

Nominal pipe size (NPS)		Outside Diameter D	Diameter of Lap(G)			Length(F)		Radius of Fillet(R)	
A	B		JIS		JPI	JIS	JPI	JIS	JPI
			5K	10K					
15	1/2	21.7	44	51	35	30	50	3	3.2
20	1/4	27.2	49	56	43	30	50	3	3.2
25	1	34	59	67	51	50	50	3	3.2
32	1 1/4	42.7	70	76	64	50	50	4	4.8
40	1 1/2	48.6	75	81	73	50	50	4	6.4
50	2	60.5	85	96	92	50	65	4	7.9
65	2 1/2	76.3	110	116	105	50	65	5	7.9
80	3	89.1	121	126	127	50	65	5	9.5
90	3 1/2	-	-	-	-	-	-	-	-
100	4	114.3	141	151	157	50	75	5	11.1
125	5	139.8	176	182	186	50	75	6	11.1
150	6	165.2	206	212	216	50	90	6	12.7
200	8	216.3	252	262	270	65	100	6	12.7
250	10	267.4	317	324	324	65	125	6	12.7
300	12	318.5	360	368	381	65	150	8	12.7
350	14	355.6	403	413	-	150	-	8	-
400	16	406.4	463	475	-	150	-	8	-
450	18	457.2	523	530	-	150	-	8	-
500	20	508	573	585	-	150	-	8	-
550	22	558.8	630	640	-	150	-	8	-
600	24	609.6	680	690	-	150	-	8	-

Steel Butt-Welding Pipe Fittings(JIS)
Reducing Tees and Concentric & Eccentric Reducers

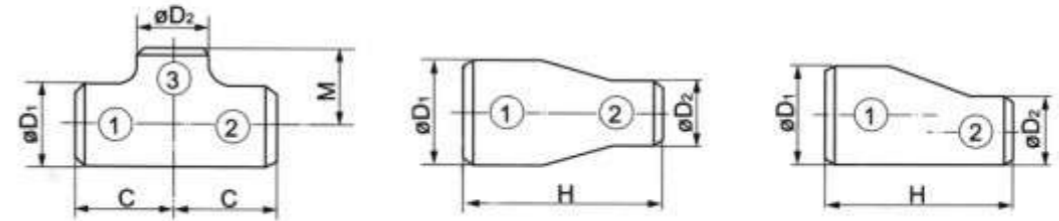

JIS B2311

Unit:mm

Nominal Pipe Size(NPS)		Outside Diameter		Reducing Tees		Reducers
A	B	D	D ₁	Center-to-End		End-to-End
				C	M	H
20×15	1/2×1/4	27.2	21.7	28.6	28.6	38.1
25×20	1×1/4	34.0	27.2	38.1	38.1	50.8
25×15	1×1/2	34.0	21.7	38.1	38.1	50.8
32×25	1 1/4×1	42.7	34.0	47.6	47.6	50.8
32×20	1 1/4×1/2	42.7	27.2	47.6	47.6	50.8
32×15	1 1/4×1/4	42.7	21.7	47.6	47.6	50.8
40×32	1 1/2×1 1/4	48.6	42.7	57.2	57.2	63.5
40×25	1 1/2×1	48.6	34.0	57.2	57.2	63.5
40×20	1 1/2×1/2	48.6	27.2	57.2	57.2	63.5
40×15	1 1/2×1/4	48.6	21.7	57.2	57.2	63.5
50×40	2×1 1/2	60.5	48.6	63.5	60.3	76.2
50×32	2×1 1/4	60.5	42.7	63.5	57.2	76.2
50×25	2×1	60.5	34.0	63.5	50.8	76.2
50×20	2×1/2	60.5	27.2	63.5	44.5	76.2
50×15	2×1/4	60.5	21.7	63.5	*	76.2
65×50	2 1/2×2	76.3	60.5	76.2	69.9	88.9
65×40	2 1/2×1 1/2	76.3	48.6	76.2	66.7	88.9
65×32	2 1/2×1 1/4	76.3	42.7	76.2	63.5	88.9
65×25	2 1/2×1	76.3	34.0	76.2	57.2	88.9
65×20	2 1/2×1/2	76.3	27.2	76.2	*	88.9
65×15	2 1/2×1/4	76.3	21.7	76.2	*	88.9
80×65	3×2 1/2	89.1	76.3	85.7	82.6	88.9
80×50	3×2	89.1	60.5	85.7	76.2	88.9
80×40	3×1 1/2	89.1	48.6	85.7	73.0	88.9
80×32	3×1 1/4	89.1	42.7	85.7	69.9	88.9
80×25	3×1	89.1	34.0	85.7	*	88.9
80×20	3×1/2	89.1	27.2	85.7	*	88.9
80×15	3×1/4	89.1	21.7	85.7	*	88.9
90×80	3 1/2×3	101.6	89.1	95.3	92.1	101.6
90×65	3 1/2×2 1/2	101.6	76.3	95.3	88.9	101.6
90×50	3 1/2×2	101.6	60.5	95.3	82.9	101.6
90×40	3 1/2×1 1/2	101.6	48.6	95.3	79.4	101.6
90×32	3 1/2×1 1/4	101.6	42.7	95.3	*	101.6
100×90	4×3 1/2	114.3	101.6	104.8	101.6	101.6
100×80	4×3	114.3	89.1	104.8	98.4	101.6
100×65	4×2 1/2	114.3	76.3	104.8	95.3	101.6
100×50	4×2	114.3	60.5	104.8	88.9	101.6
100×40	4×1 1/2	114.3	48.6	104.8	85.7	101.6
100×32	4×1 1/4	114.3	42.7	104.8	*	101.6
100×25	4×1	114.3	34.0	104.8	*	101.6

Steel Butt-Welding Pipe Fittings (JIS)
Reducing Tees and Concentric & Eccentric Reducers

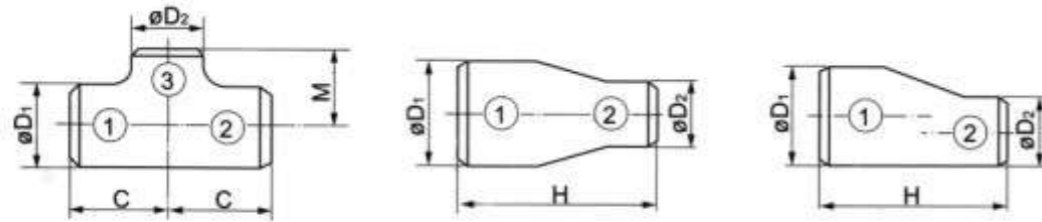

JIS B2311 Unit:mm

Nominal Pipe Size(NPS)		Outside Diameter		Reducing Tees		Reducers
A	B	D ₁	D ₂	Center-to-End		End-to-End
A	B	D ₁	D ₂	C	M	H
125×100	5×4	139.8	114.3	123.8	117.5	127.0
125×90	5×3½	139.8	101.6	123.8	114.3	127.0
125×80	5×3	139.8	89.1	123.8	111.1	127.0
125×65	5×2½	139.8	76.3	123.8	108.0	127.0
125×50	5×2	139.8	60.5	123.8	104.8	127.0
125×40	5×1½	139.8	48.6	123.8	*	127.0
125×32	5×1¼	139.8	42.7	123.8	*	127.0
150×125	6×5	165.2	139.8	142.9	136.5	139.7
150×100	6×4	165.2	114.3	142.9	130.2	139.7
150×90	6×3½	165.2	101.6	142.9	127.0	139.7
150×80	6×3	165.2	89.1	142.9	123.8	139.7
150×65	6×2½	165.2	76.3	142.9	120.7	139.7
150×50	6×2	165.2	60.5	142.9	*	139.7
200×150	8×6	216.3	165.2	177.8	168.3	152.4
200×125	8×5	216.3	139.8	177.8	161.9	152.4
200×100	8×4	216.3	114.3	177.8	155.6	152.4
200×90	8×3½	216.3	101.6	177.8	152.4	152.4
200×80	8×3	216.3	89.1	177.8	152.4	152.4
250×200	10×8	267.4	216.3	215.9	203.2	177.8
250×150	10×6	267.4	165.2	215.9	193.7	177.8
250×125	10×5	267.4	139.8	215.9	190.5	177.8
250×100	10×4	267.4	114.3	215.9	184.2	177.8
250×80	10×3	267.4	89.1	215.9	*	177.8
300×250	12×10	318.5	267.4	254.0	241.3	203.2
300×200	12×8	318.5	216.3	254.0	228.6	203.2
300×150	12×6	318.5	165.2	254.0	29.1	203.2
300×125	12×5	318.5	139.8	254.0	215.9	203.2
300×100	12×4	318.5	114.3	254.0	*	203.2
350×300	14×12	355.6	318.5	279.4	269.9	330.2
350×250	14×10	355.6	267.4	279.4	257.2	330.2
350×200	14×8	355.6	216.3	279.4	247.7	330.2
350×150	14×6	355.6	165.2	279.4	238.1	330.2
350×125	14×5	355.6	139.8	279.4	*	330.2
400×350	16×14	406.4	355.6	304.8	304.8	355.6
400×300	16×12	406.4	318.5	304.8	295.3	355.6
400×250	16×10	406.4	267.4	304.8	282.6	355.6
400×200	16×8	406.4	216.3	304.8	273.1	355.6
400×150	16×6	406.4	165.2	304.8	263.5	355.6

Steel Butt-Welding Pipe Fittings (JIS)
Reducing Tees and Concentric & Eccentric Reducers

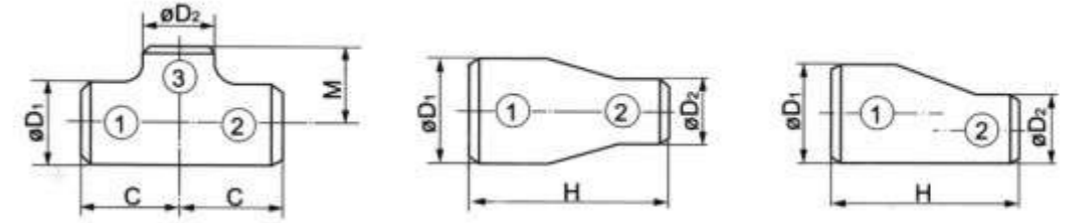

JIS B2311 Unit:mm

Nominal Pipe Size(NPS)		Outside Diameter		Reducing Tees		Reducer
A	B	D ₁	D ₂	Center-to-End		End-to-End
A	B	D ₁	D ₂	C	M	H
450×400	18×16	457.2	406.4	342.9	330.2	381.0
450×350	18×14	457.2	355.6	342.9	330.2	381.0
450×300	18×12	457.2	318.5	342.9	320.7	381.0
450×250	18×10	457.2	267.4	342.9	308.0	381.0
450×200	18×8	457.2	216.3	342.9	298.0	381.0
500×450	20×18	508.0	457.2	381.0	368.3	508.0
500×400	20×16	508.0	406.4	381.0	355.6	508.0
500×350	20×14	508.0	355.6	381.0	355.6	508.0
500×300	20×12	508.0	318.5	381.0	346.1	508.0
500×250	20×10	508.0	267.4	381.0	333.4	508.0
500×200	20×8	508.0	216.3	381.0	523.9	508.0
550×500	22×20	558.8	508.0	419.1	406.4	508.0
550×450	22×18	558.8	457.2	419.1	393.7	508.0
550×400	22×16	558.8	406.4	419.1	381.0	508.0
550×350	22×14	558.8	355.6	419.1	381.0	508.0
600×550	24×22	609.6	558.8	431.8	431.8	508.0
600×500	24×20	609.6	508.0	431.8	431.8	508.0
600×450	24×18	609.6	457.2	431.8	419.1	508.0
600×400	24×16	609.6	406.4	431.8	406.4	508.0
600×350	24×14	609.6	355.6	431.8	406.4	508.0
600×300	24×12	609.6	318.5	431.8	397.0	508.0
650×600	26×24	660.4	609.6	495.3	482.6	609.6
650×550	26×22	660.4	558.8	495.3	469.9	609.6
650×500	26×20	660.4	508.0	495.3	457.2	609.6
650×450	26×18	660.4	457.2	495.3	440.0	609.6
700×650	28×26	711.2	660.4	520.7	520.7	609.6
700×600	28×24	711.2	609.6	520.7	508.0	609.6
700×550	28×22	711.2	558.8	520.7	495.3	609.6
700×500	28×20	711.2	508.0	520.7	483.0	609.6
750×700	30×28	762.0	711.2	558.8	546.1	609.6
750×650	30×26	762.0	660.4	558.8	546.1	609.6
750×600	30×24	762.0	609.6	558.8	533.4	609.6
750×550	30×22	762.0	558.8	558.8	520.7	609.6
800×750	32×30	812.8	762.0	596.9	584.2	609.6
800×700	32×28	812.8	711.2	596.9	571.5	609.6
800×650	32×26	812.8	660.4	596.9	571.5	609.6
800×600	32×24	812.8	609.6	596.9	559.0	609.6

Steel Butt-Welding Pipe Fittings(JIS)
Reducing Tees and Concentric & Eccentric Reducers

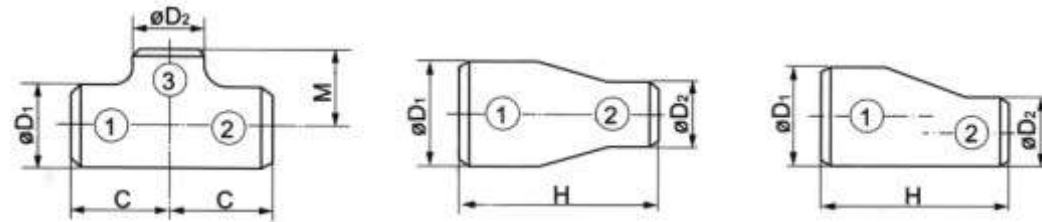

JIS B2311

Unit:mm

Nominal Pipe Size(NPS)		Outside Diameter		Reducing Tees		Reducers
A	B	D ₁	D ₂	Center-to-End		End-to-End
A	B	D ₁	D ₂	C	M	H
850×800	34×32	863.6	812.8	635.0	622.3	609.6
850×750	34×30	863.6	762.0	635.0	609.6	609.6
850×700	34×28	863.6	711.2	635.0	596.9	609.6
850×650	34×26	863.6	660.4	635.0	596.9	609.6
900×850	36×34	914.4	863.6	673.1	660.4	609.6
900×800	36×32	914.4	812.8	673.1	647.7	609.6
900×750	36×30	914.4	762.0	673.1	635.0	609.6
900×700	36×28	914.4	711.2	673.1	622.3	609.6
950×900	38×36	965.2	914.4	711.2	711.2	609.6
950×850	38×34	965.2	863.6	711.2	698.5	609.6
950×800	38×32	965.2	812.8	711.2	685.8	609.6
950×750	38×30	965.2	762.0	711.2	673.0	609.6
1000×950	40×38	1016.0	965.2	749.3	749.3	609.6
1000×900	40×36	1016.0	914.4	749.3	736.6	609.6
1000×850	40×34	1016.0	863.6	749.3	723.9	609.6
1000×800	40×32	1016.0	812.8	749.3	711.2	609.6
1050×1000	42×40	1066.8	1016.0	762.0	711.2	609.6
1050×950	42×38	1066.8	965.2	762.0	711.2	609.6
1050×900	42×36	1066.8	914.4	762.0	711.2	609.6
1050×850	42×34	1066.8	863.6	762.0	711.2	609.6
1100×1050	44×42	1117.6	1066.8	812.8	762.0	609.6
1100×1000	44×40	1117.6	1016.0	812.8	749.3	609.6
1100×950	44×38	1117.6	965.2	812.8	736.6	609.6
1100×900	44×36	1117.6	914.4	812.8	723.9	609.6
1150×1100	46×44	1168.4	1117.6	850.9	811.1	711.2
1150×1050	46×42	1168.4	1066.8	850.9	787.4	711.2
1150×1000	46×40	1168.4	1016.0	850.9	774.7	711.2
1150×950	46×38	1168.4	965.2	850.9	762.0	711.2
1200×1150	48×46	1219.2	1168.4	889.0	838.2	711.2
1200×1100	48×44	1219.2	1117.6	889.0	838.2	711.2
1200×1050	48×42	1219.2	1066.8	889.0	812.8	711.2
1200×1000	48×40	1219.2	1016.0	889.0	812.8	711.2

Steel Butt-Welding Pipe Fittings(DIN)
Elbows, Bends, and Caps

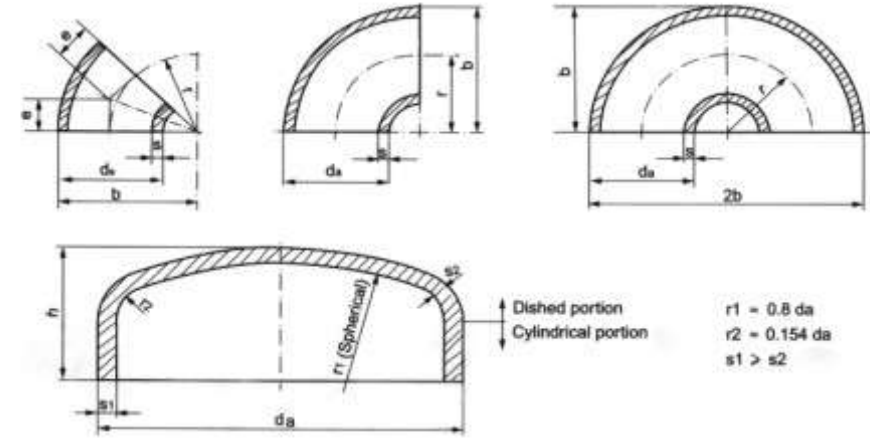

DIN 2805 DIN 28 17

Unit:mm

Nominal Size DN	Outside Diameter da	Elbows and Bends						Caps h
		Type3--3D			Type5--5D			
		r	b	e	r	b	e	
15	21.3	28.0	38	12	42.5	53	18	25
20	26.9	29.0	43	12	57.5	71	24	25
25	33.7	38.0	56	16	72.5	90	30	38
32	42.4	48.0	69	20	92.5	114	38	38
40	48.3	57.0	82	24	107.5	132	45	38
50	60.3	76	106	32	135	165	56	38
65	76.1	95	133	39	175	213	73	38
80	88.9	114	159	47	205	250	85	51
100	114.3	152	210	63	270	327	112	64
125	139.7	190	260	79	330	400	137	76
150	168.3	229	313	95	390	474	162	89
200	219.1	305	414	126	510	620	211	102
250	273	381	518	158	650	787	269	127
300	323.9	457	619	189	775	937	321	152
350	355.6	533	711	221	850	1028	352	165
400	406.4	610	813	253	970	1173	402	178
450	457	686	914	284	1122	1350	465	203
500	508	762	1016	316	1245	1500	516	229
600	610	914	1219	379	1525	1830	632	267
700	711	1067	1422	442	1778	2133	737	267
800	813	1219	1626	505	2033	2439	842	267
900	914	1372	1829	568	2285	2742	947	267
1000	1016	1524	2032	631	2540	3048	1052	305
1200	1220	1830	2440	758	3050	3660	1263	343

**Steel Butt-welding Pipe Fittings (DIN)
Tees and Concentric & Eccentric Reducers**

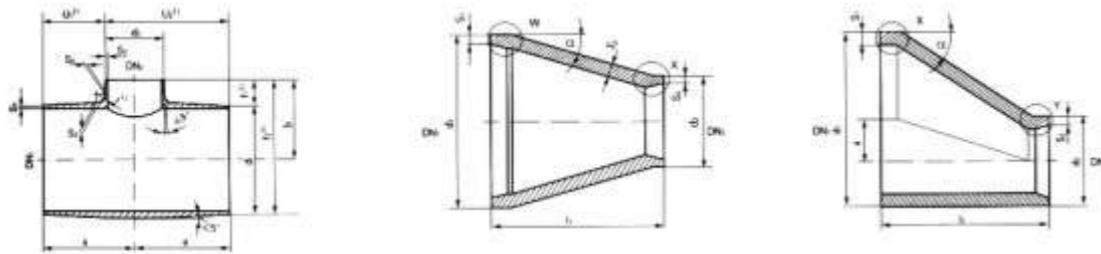

DIN2615 DIN2616

Unit:mm

Nominal Size DN1	Outside Diameter d1	Nominal Size DN2	Outside Diameter d2	Tees		Reducers
				a	b	
15	21.3	15	21.3	25	25	38
20	26.9	20	26.9	29	29	38
20	26.9	15	21.3	29	29	38
25	33.7	25	33.7	38	38	50
25	33.7	20	26.9	38	38	50
25	33.7	15	21.3	38	38	50
32	42.4	32	42.4	48	48	50
32	42.4	25	33.7	48	48	50
32	42.4	20	26.9	48	48	50
32	42.4	15	21.3	48	48	50
40	48.3	40	48.3	57	57	64
40	48.3	32	42.4	57	57	64
40	48.3	25	33.7	57	57	64
40	48.3	20	26.9	57	57	64
50	60.3	50	60.3	64	64	76
50	60.3	40	48.3	64	60	76
50	60.3	32	42.4	64	57	76
50	60.3	25	33.7	64	51	76
50	60.3	20	26.9	64	44	76
65	76.1	65	76.1	76	76	90
65	76.1	50	60.3	76	70	90
65	76.1	40	48.3	76	67	90
65	76.1	32	42.4	76	64	90
65	76.1	25	33.7	76	57	90
80	88.9	80	88.9	86	86	90
80	88.9	65	76.1	86	83	90
80	88.9	50	60.3	86	76	90
80	88.9	40	48.3	86	73	90
80	88.9	32	42.4	86	70	90
100	114.3	100	114.3	105	105	100
100	114.3	80	88.9	105	98	100
100	114.3	65	76.1	105	95	100
100	114.3	50	60.3	105	89	100
100	114.3	40	48.3	105	86	100
125	139.7	125	139.7	124	124	127
125	139.7	100	114.3	124	117	127
125	139.7	80	88.9	124	111	127
125	139.7	65	76.1	124	108	127
125	139.7	50	60.3	124	105	127
150	168.3	150	168.3	143	143	140
150	168.3	125	139.7	143	137	140

**Steel Butt-welding Pipe Fittings (DIN)
Tees and Concentric & Eccentric Reducers**

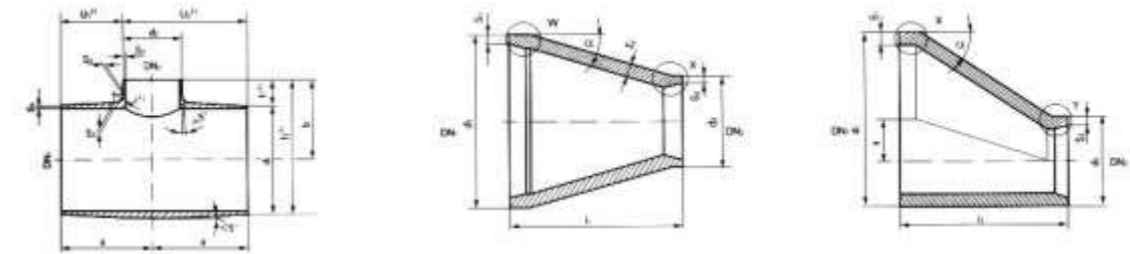

DIN2615 DIN2616

Unit:mm

Nominal Size DN1	Outside Diameter d1	Nominal Size DN2	Outside Diameter d2	Tees		Reducers
				a	b	
150	168.3	100	114.3	143	130	140
150	168.3	80	88.9	143	124	140
150	168.3	65	76.1	143	121	140
200	219.1	200	219.1	178	178	152
200	219.1	150	168.3	178	168	152
200	219.1	125	139.7	178	162	152
200	219.1	100	114.3	178	156	152
200	219.1	80	88.9	178	152	152
250	273	250	273	216	216	178
250	273	200	219.1	216	203	178
250	273	150	168.3	216	194	178
250	273	125	139.7	216	191	178
250	273	100	114.3	216	184	178
300	323.9	300	323.9	254	254	203
300	323.9	250	273	254	241	203
300	323.9	200	219.1	254	229	203
300	323.9	150	168.3	254	219	203
300	323.9	125	139.7	254	216	203
350	355.6	350	355.6	279	279	330
350	355.6	300	323.9	279	270	330
350	355.6	250	273	279	257	330
350	355.6	200	219.1	279	248	330
350	355.6	150	168.3	279	238	330
400	406.4	400	406.4	305	305	355
400	406.4	350	355.6	305	305	355
400	406.4	300	323.9	305	295	355
400	406.4	250	273	305	283	355
400	406.4	200	219.1	305	273	355
400	406.4	150	168.3	305	264	355
450	457	450	457	343	343	381
450	457	400	406.4	343	330	381
450	457	350	355.6	343	330	381
450	457	300	323.9	343	321	381
450	457	250	273	343	308	381
450	457	200	219.1	343	298	381
500	508	500	508	381	381	508
500	508	450	457	381	368	508
500	508	400	406.4	381	356	508
500	508	350	355.6	381	356	508
500	508	300	323.9	381	346	508
500	508	250	273	381	333	508

**Steel Butt-welding Pipe Fittings(DIN)
Tees and Concentric & Eccentric Reducers**

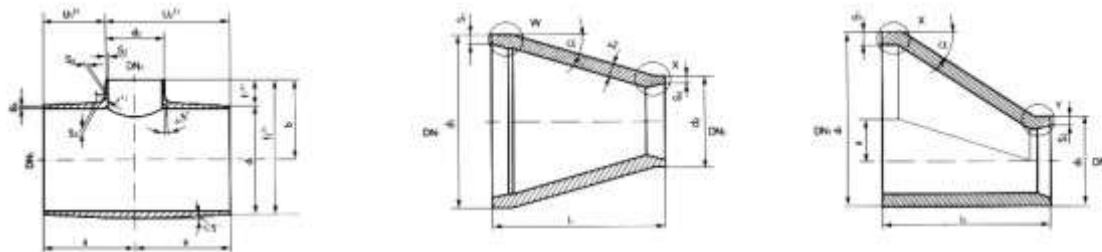

DIN 2615 DIN2616

Unit:mm

Nominal Size DNI	Outside Diameter d1	Nominal Size DN2	Outside Diameter d2	Tees		Reducers
				a	b	ll
500	508	200	219.1	381	324	508
600	610	600	610	432	432	508
600	610	500	508	432	432	508
600	610	450	457	432	419	508
600	610	400	406.4	432	406	508
600	610	350	355.6	432	406	508
600	610	300	323.9	432	397	508
600	610	250	273	432	384	508
700	711	700	711	521	521	610
700	711	600	610	521	508	610
700	711	500	508	521	483	610
700	711	450	457	521	470	610
700	711	400	406.4	521	457	610
700	711	350	355.6	521	457	610
700	711	300	323.9	521	448	610
800	813	800	813	597	597	610
800	813	700	711	597	572	610
800	813	600	610	597	559	610
800	813	500	508	597	533	610
800	813	450	457	597	521	610
800	813	400	406.4	597	508	610
800	813	350	355.6	597	508	610
900	914	900	914	673	673	610
900	914	800	813	673	648	610
900	914	700	711	673	622	610
900	914	600	610	673	610	610
900	914	500	508	673	584	610
900	914	450	457	673	572	610
900	914	400	406.4	673	559	610
1000	1016	1000	1016	749	749	610
1000	1016	900	914	749	737	610
1000	1016	800	813	749	711	610
1000	1016	700	711	749	673	610
1000	1016	600	610	749	660	610
1000	1016	500	508	749	635	610
1000	1016	450	457	749	622	610
1200	1220	1200	1220	889	838	711
1200	1220	1000	1016	889	813	711
1200	1220	900	914	889	787	711
1200	1220	800	813	889	787	711
1200	1220	700	711	889	762	711
1200	1220	600	610	889	737	711

Welding End Preparation

ASME B16.9, B16.25

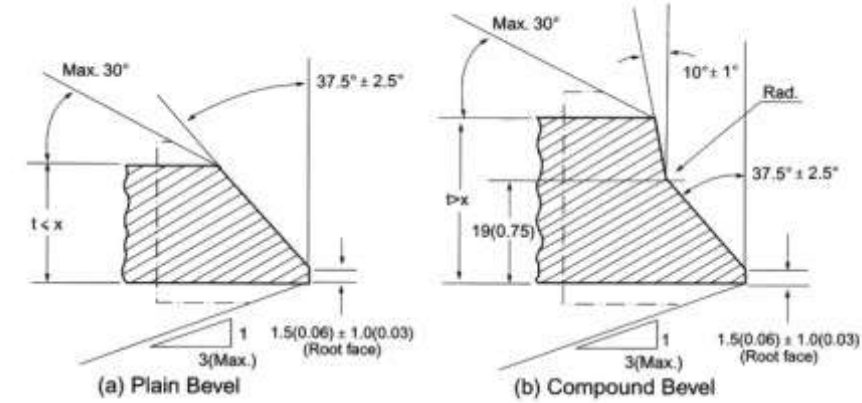

Welding Bevels and Root Face

Nominal Wall Thickness, t	End Preparation
Less than x [Note]	Cut square or slightly chamfer, at manufacturer's option. (Not illustrated.)
x to 22 (0.88)	Plain bevel as in sketch (a) above.
More than 22 (0.88)	Compound bevel as in sketch (b) above.

GENERAL NOTES: Dimensions in parentheses are in inches. Others are in Millimeters.

NOTE: x=5(0.19) for carbon steel or ferritic alloy steel

x=3(0.12) for austenitic alloy steel

JIS B2311

Unit:mm

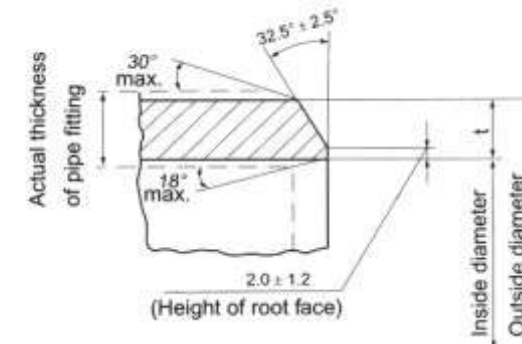

Shape and Dimensions of Bevel End

Dimensional Tolerances(ASME)

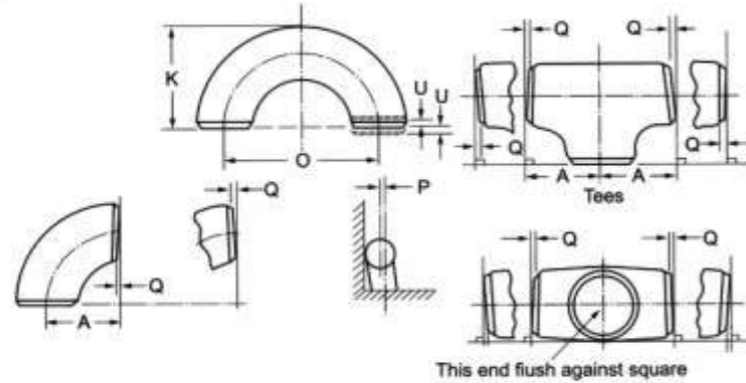

ASME B16.9, B16.28

Pipe Size	All Fittings				Wall Thickness t	90° & 45° Elbows and Tees		Reducers and Lap Joint Stub ends		Caps	
	Outside Diameter at Bevel, D(1)		Inside Diameter at End (1)			Center-to-End Dimensions A, B, C, M		Overall Length, F, H		Overall Length, E	
	IN	MM	IN	MM		IN	MM	IN	MM	IN	MM
1/2-2 1/2	+0.06 -0.03	+1.6 -0.8	±0.03	±0.8	Not Less Than 87.5% of Nominal Thickness	±0.06	±2	±0.06	±2	±0.12	±3
3-2 1/2	±0.06	±1.6	±0.06	±1.6						±0.09	±0.09
4	+0.09 -0.06	+2.4 -1.6				±0.12	±3.2	±0.12	±3		
5-8	+0.16 -0.12	+4.0 -3.2	±0.19	±4.8						±0.12	±3
10-18	+0.25 -0.19	+6.4 -4.8				±0.19	±4.8	±0.12	±3		
20-24			±0.19	±4.8						±0.12	±3
26-30						±0.19	±4.8	±0.12	±3		
32-48			±0.19	±4.8	±0.12					±3	±0.19

Pipe Size	Lap Joint Stub Ends (2)				180 Return Bends							
	Outside Diameter of Lap, G		Lap Thickness		Fillet Radius of Lap, R		Center-to-Center Dimension, O		Back-to-Face Dimension, K		Alignment of Ends, U	
	IN	MM	IN	MM	IN	MM	IN	MM	IN	MM	IN	MM
1/2-2 1/2					+0	+0	±0.25	±6	±0.25	±6	0.03	±1
3-2 1/2	+0	+0	+0.06	+1.6	-0.03	-1						
4	-0.03	-1	-0	-0	+0	+0	±0.38	±10			±0.06	±2
5-8												
10-18	+0	+0	+0.12	+3.2								
20-24	-0.06	-2	-0	-0								

Pipe Size	Off Angle, O		Off Plane, P	
	IN	MM	IN	MM
1/2-4	±0.03	±1	±0.06	±2
5-8	±0.06	±2	±0.12	±4
10-12	±0.09	±3	±0.19	±5
14-16			±0.25	±6
18-24	±0.12	±4	±0.38	±10
26-30	±0.19	±5	±0.50	±13
32-42			±0.75	±19
44-48				

NOTES:

- (1) Out-of-round is the sum of absolute values of plus and minus tolerances.
- (2) Outside diameter of barrel see the table on page 14.

Dimensional Tolerances(MSS)

MSS SP-43

Nominal Pipe Size	All Fittings		90° Elbows	45° Elbows	Reducers	180° Returns	Caps	Lap-Joint Stub Ends		
	Outside Diameter at Welding End(a)	Wall Thickness	Center-to-End A-B-C-M	Overall Length F-H	Center-to-Center O	Back-to-Face K	Alignment of Ends U	Overall Length E	Fillet(b) Radius of Lap A	Outside Diameter of Lap G
1/2-1 1/2	±0.03 (±0.8)	Not less than 87.5% of nominal thickness	±0.06 (±1.6)	±0.25 (±6.4)	±0.03 (±0.8)	±0.25 (±6.4)	±0.12 (±3.2)	±0.03 (±0.8)	+0 -0.03 (+0) (-0.8)	+0 -0.03 (+0) (-0.8)
2-3 1/2										
4										
5-8										
10-18										
20-24										
26-30										
32-48										

GENERAL NOTE:

All dimensions are in inches. Dimensions in brackets are in millimeters for reference only.

NOTES:

- (a) Out of roundness is the vector sum of plus and minus tolerance.
- (b) Fillet R radius is maximum. See page 17.

Dimensional Tolerances(JIS)

JIS B2311

Item	Types of pipe fittings	Nominal diameter						
		A 15~ 65 1/2~2 1/2	80~ 100	125~ 200	250~ 450	500~ 600	650~ 750	800~ 1200
		B 1 1/2~ 2 1/2	3~4	5~8	10~ 18	20~ 24	26~ 30	32~ 48
		Tolerance						
Outside diameter at end	All types of pipe fittings	±2.0	±2.5	±3.5	+5.0 -4.5		+6.4 -4.8	
Inside diameter at end face					±4.5		±4.8	
Thickness		+Not specific -15%						
Bevel angle		See figure Shape and Dimensions of Bevel End on page						
Height of root face		See figure Shape and Dimensions of Bevel End on page						
Dimension from center line to end face(H,F)	45° elbows 90° elbows	±2.0			±3.2			±4.8
Centerline dimension(P)		±6.4		±9.5				-
Dimension from back to end face(K)		±6.4						-
Alignment of end faces(U) (max.)	180° elbows	1.6		3.2				-
Overall length(H)	Reducers			±3.2				±4.8
Dimension from centerline to end face(C,M)	Tees	±2.0		±3.2				±4.8
Dimension from back to end face(E)	Caps	±3.2		±6.4				-
Outer peripheral length at end	All types of pipe fittings							±0.5%

Remarks 1 For the dimensional tolerances for H of reducer and M of reduced tee, the tolerances specified for larger diameter side shall apply.
2 For the galvanized part of white pipe fittings, the above-mentioned tolerance shall be applied before galvanizing.

Dimensional Tolerances(JIS)

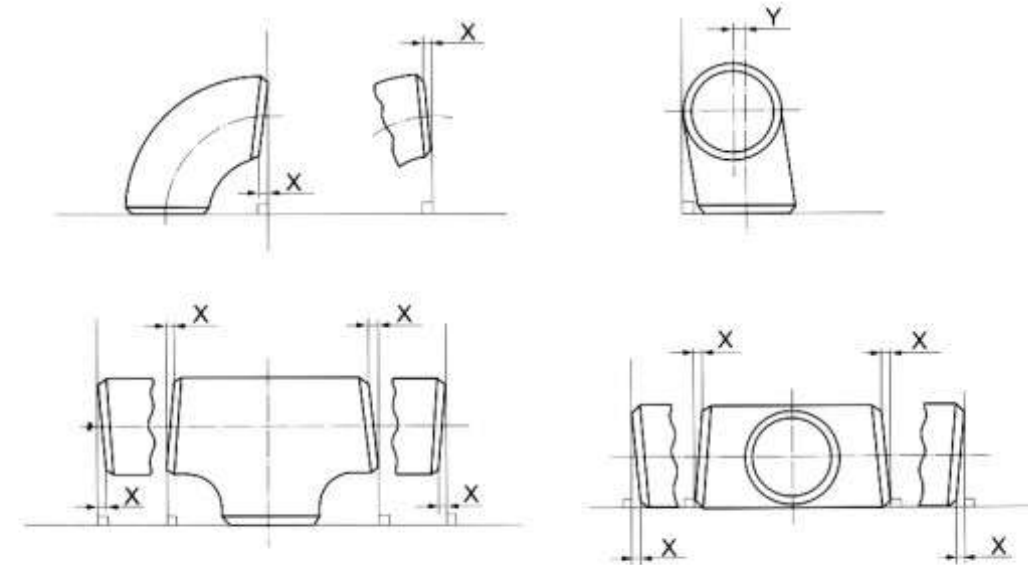

JIS B2311

Item	Types of pipe fitting	Nominal diameter							
		A 15~ 100	125~ 200	250~ 300	350~ 400	450~ 600	650~ 750	800~ 1050	1100~ 1200
		B 1 1/2~ 4	5~8	10~12	14~ 16	18~ 24	26~ 30	32~ 42	44~ 48
		Tolerance							
Off angle(X)	Elbws, reducers, tees	0.8	1.6	2.4		3.2	4.8		
Off plane(Y)	Elbow s, tees	1.6	3.2	4.8	6.4	9.5		12.7	19.1

Remarks 1 For the tolerances on alignment of reducer and reduced tee, the tolerances specified for larger diameter side shall apply.
2 For the galvanized part of white pipe fittings, the above-mentioned tolerance shall be applied before galvanizing.

MATERIAL SPECIFICATIONS FOR BUTT-WELDING FITTINGS(ASTM)

ASTM A234/A234M-00a

Piping Fittings of Wrought Carbon Steel and Alloy Steel for Moderate and High Temperature Service

Grade	Composition, %										
	C	Mn	P	S	Si	Cr	Mo	Ni	Cu	V	Nb
WPB(1)(2)(3)(4)	0.30	0.29-1.06	0.050	0.058	0.10	0.40	0.15	0.40	0.40	0.08	0.02
WPC(1)(2)(3)(4)	0.35	0.29-1.06	0.050	0.058	0.10	0.40	0.15	0.40	0.40	0.08	0.02
WP11 CL1	0.05-0.15	0.30-0.80	0.030	0.030	0.50-1.00	1.00-1.50	0.44-0.65	-	-	-	-
WP11 CL2	0.05-0.20	0.30-0.80	0.040	0.040	0.50-1.00	1.00-1.50	0.44-0.65	-	-	-	-
WP11 CL3	0.05-0.20	0.30-0.80	0.040	0.040	0.50-1.00	1.00-1.50	0.44-0.65	-	-	-	-

GENERAL NOTE:
All values are maximum unless otherwise indicated.

- NOTES:
(1) For each reduction of 0.01% below the specified C maximum, an increase of 0.06% Mn above the specified maximum will be permitted, up to a maximum of 1.35%.
(2) The sum of Cu, Ni, Cr, and Mo shall not exceed 1.00%.
(3) The sum of Cr and Mo shall not exceed 0.32%.
(4) The maximum carbon equivalent (C.E.) shall be 0.50, based on heat analysis and the formula $C.E. = C + Mn/8 + (Cr + Mo + V)/5 + (Ni + Cu)/15$.

Tensile Requirements	WPB	WPC, WP11CL2	WP11CL1	WP11CL3
Tensile Strength, min, ksi[MPa] (0.2% offset or 0.5% Extension Under Load)	60-85 [415-585]	70-95 [485-655]	60-85 [415-585]	75-100 [520-690]
Yield Strength, min, ksi[MPa]	32 [240]	40 [275]	30 [205]	45 [310]

	Wall thickness		Elongation Requirements	
	in	mm	Longitudinal	Transverse
Standard rounds specimen, or small proportional specimen, min % in 4D			22	14
Rectangular Specimen for wall thickness 0.312in [7.94mm] and over, and for all small sizes tested in full section; min % in 2in [50mm]	≥0.312	≥7.94	30	20
Rectangular Specimen for wall thickness less than 0.312in [7.94mm]; min % in 2in [50mm] (0.5in [12.7mm] wide specimen)	0.281	7.14	28.5	19
	0.250	6.35	27.0	18
	0.219	5.56	25.5	-
	0.188	4.76	24.0	-
	0.156	3.97	22.5	-
	0.125	3.17	21.0	-
	0.094	2.38	19.5	-
	0.062	1.59	18.0	-

Where the wall thickness lies between two values above, the min elongation value is determined by the following equations:

Longitudinal $E = 48t + 15.00$
Transverse $E = 32t + 10.00$

E = elongation in 2in [50mm], %
t = actual thickness of specimen, in [mm]

Material Specifications for Butt-Welding Fittings (JIS and DIN)

JIS B2311 Steel Butt-Welding Pipe Fittings for Ordinary Use
JIS G3452 Carbon Steel Pipes for Ordinary Piping
JIS G3457 Arc Welded Carbon Steel Pipes

Steel Grade	Chemical Composition %			Tensile Strength	Yield Point	Elongation % (1)	
	C	p	S	N/mm ² Min	Point	Longitudinal	Transverse
	Max					Min	Min
SGP	-	0.040	0.040	290	-	30 ₍₂₎	25 ₍₂₎
PY400	0.25	0.040	0.040	400	255	-	18

- NOTES:
(1) Values specified are for wall thickness 8mm and over. For each 1mm decrease in wall thickness below 8mm, a deduction of 1.5% for both longitudinal and transverse from the values shown above is permitted.
(2) Values not applicable to NPS below 32A.

DIN 1626 Welded Circular Unalloyed Steel Tubes Subject to Special Requirements
DIN 1629 Seamless Circular Unalloyed Steel Tubes Subject to Special Requirements
DIN 17175 Seamless Tubes of Heat-Resistant Steels

Steel Grade Symbol	Type of deoxidization	Chemical Composition (cast analysis) % (max unless otherwise specified)					
		C	Si(1)	Mn	P	S	N ₍₂₎
St 37.0	R	0.17	-	-	0.040	0.040	0.009 ₍₃₎
St 35.8	-	0.17	0.10-0.35	0.40-0.80	0.040	0.040	-

- NOTES:
(1) The minimum Si content is allowed to fall below 0.10%, when the steel is aluminum-killed or vacuum-deoxidized.
(2) A content in excess of the maximum value stated is permitted if a P content less than the maximum specified by 0.005% P per 0.001% N is observed. However the N content shall not exceed a value of 0.012% in the case analysis and 0.014% in the product analysis.
(3) The specified value does not apply if the steels are supplied with the RR (instead of R) type of deoxidization.
R=killed, including semi-killed
RR=fully killed

Amounts by which the chemical composition in the product/sample analysis may deviate from the limiting values applicable to the cast analysis.

Element	St 37.0	St 35.8	
	Allowable Deviation Amount %	Limits Quoted in Cast Analysis	Allowable Deviation Amount, %
C	0.02	≤0.24	±0.02
Si	-	≤0.35	±0.03
Mn	-	≤1.00	±0.04
P	0.010	≤0.040	±0.010
S	0.010	≤0.040	±0.010
N	0.001(1)	-	-

- NOTES:
(1) A content in excess of the maximum value stated is permitted if a P content less than the maximum specified by 0.005% P per 0.001% N is observed. However the N content shall not exceed a value of 0.012% in the case analysis and 0.014% in the product analysis (this does not apply to the RR type of deoxidization).
(2) In a cast the deviation of an element in a sample analysis is permitted to be below the minimum value or only above the maximum value of the range stipulated for the cast analysis, though not both at the same time.

Steel Grade Symbol	Upper Yield Stress ReH for Wall thicknesses, in mm			Tensile Strength Rm	Elongation after Fracture A5		Impact Strength Transverse Min J
	ReH ≤ 16	16 < ReH ≤ 40	40 < ReH ≤ 60		Longitudinal	Transverse	
	Min N/mm ²			Min %			
St 37.0	235	225	215	350(1)-480	25	23	-
St 35.8	235	225	215	360-480	25	23	34

- NOTE:
(1) For cold finished tubes in the NBK condition, minimum values of tensile strength lower than this value by 10N/mm² is permitted.

TECHNICAL DATA

MILD STEEL PLATE FLANGE DIN

PN10 PLFF (NP 10kg/cm ²)									
NOMINAL PIPE SIZE		OUTER DIAMETER O (mm)	INTERNAL DIAMETER C (mm)	THICKNESS T (mm)	NO. OF BOLT HOLES	DIAMETER OF BOLT HOLES J (mm)	DIAMETER OF BOLT HOLE K (mm)	APPROXIMATE WEIGHT (kg)	
mm	Inch							FLAT FACE	BLIND
15	1/2	95	22.0	14	4	14	65	0.67	
20	3/4	105	27.6	16	4	14	75	0.94	
25	1	115	34.4	16	4	14	85	1.11	
32	1 1/4	140	43.1	16	4	18	100	1.62	
40	1 1/2	150	49.0	16	4	18	110	1.86	
50	2	165	61.1	18	4	18	125	2.47	
65	2 1/2	185	77.1	18	4	18	145	3.00	
80	3	200	90.3	20	4	18	160	3.79	
100	4	220	115.9	20	8	18	180	4.03	
125	5	250	144.6	22	8	18	210	5.46	
150	6	285	170.5	24	8	22	240	7.15	
200	8	340	221.8	24	8	22	295	9.27	
250	10	395	276.2	26	12	22	350	11.85	
300	12	445	327.6	28	12	22	400	14.65	
350	14	505	359.7	28	16	22	460	20.35	
400	16	565	411.0	32	16	26	515	27.90	
450	18	615	462.3	34	20	26	565	31.65	
500	20	670	513.0	38	20	26	620	41.10	
600	24	780	613.0	42	20	30	725	55.60	

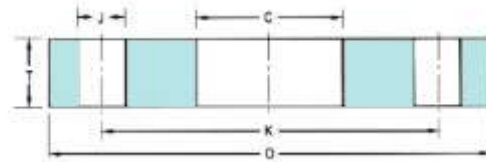

PN16 PLFF (NP 16kg/cm ²)									
NOMINAL PIPE SIZE		OUTER DIAMETER O (mm)	INTERNAL DIAMETER C (mm)	THICKNESS T (mm)	NO. OF BOLT HOLES	DIAMETER OF BOLT HOLES J (mm)	DIAMETER OF BOLT HOLE K (mm)	APPROXIMATE WEIGHT (kg)	
mm	Inch							FLAT FACE	BLIND
15	1/2	95	22.0	14	4	14	65	0.87	0.71
20	3/4	105	27.6	16	4	14	75	0.93	1.01
25	1	115	34.4	16	4	14	85	1.11	1.23
32	1 1/4	140	43.1	16	4	18	100	1.63	1.80
40	1 1/2	150	49.0	18	4	18	110	1.92	2.09
50	2	165	61.1	18	4	18	125	2.45	2.88
65	2 1/2	185	77.1	18	4	18	145	3.03	3.65
80	3	200	90.3	20	8	18	160	3.81	4.77
100	4	220	115.9	20	8	18	180	4.00	5.65
125	5	250	144.6	22	8	18	210	5.41	8.12
150	6	285	170.5	24	8	22	240	7.81	10.5
200	8	340	221.8	26	12	22	295	9.71	17.59
250	10	405	276.2	26	12	26	355	14.72	28.83
300	12	460	327.6	28	12	26	410	16.60	35.12
350	14	520	359.7	30	16	26	470	24.08	48.01
400	16	580	411.0	32	16	30	525	30.20	63.50
450	18	640	462.3	38	20	30	585	41.67	91.74
500	20	715	513.0	38	20	33	650	53.0	114.66
600	24	840	613.0	38	20	36	770	71.19	159.23

CANGZHOU HUAYE

METAL PRODUCTS CO., LTD.

MILD STEEL PLATE FLANGE ANSI

150 LB PLFF									
NOMINAL PIPE SIZE		OUTER DIAMETER O (mm)	INTERNAL DIAMETER C (mm)	THICKNESS T (mm)	NO. OF BOLT HOLES	DIAMETER OF BOLT HOLES J (mm)	DIAMETER OF BOLT HOLE K (mm)	APPROXIMATE WEIGHT (kg)	
mm	Inch							FLAT FACE	BLIND
15	1/2	89	22.3	12	4	15.9	60.3	0.48	0.50
20	3/4	98	27.7	14	4	15.9	69.9	0.68	0.75
25	1	108	34.5	14	4	15.9	79.4	0.82	0.92
32	1 1/4	117	43.2	16	4	15.9	88.9	1.09	1.25
40	1 1/2	127	49.5	16	4	15.9	98.4	1.28	1.50
50	2	152	62.0	16	4	19.1	120.7	1.76	2.14
65	2 1/2	178	74.7	18	4	19.1	139.7	2.74	3.35
80	3	191	90.7	18	4	19.1	152.4	2.97	3.90
100	4	229	116.1	18	8	19.1	190.5	4.00	5.50
125	5	254	143.8	20	8	22.2	215.9	4.92	7.48
150	6	279	170.7	22	8	22.2	241.3	6.08	10.02
200	8	343	221.5	22	8	22.2	298.5	8.78	15.42
250	10	406	276.3	24	12	25.4	362.0	11.95	23.25
300	12	483	327.1	26	12	25.4	431.8	19	36.15
350	14	533	359.2	28	12	28.6	476.3	25.08	47.35
400	16	597	410.5	31	16	28.6	539.8	33.41	65.12
450	18	635	461.8	34	16	31.8	577.9	36.4	81.13
500	20	699	513.1	37	20	31.8	635.0	47.0	106.85
600	24	813	615.9	42	20	34.9	749.3	66.62	164.85

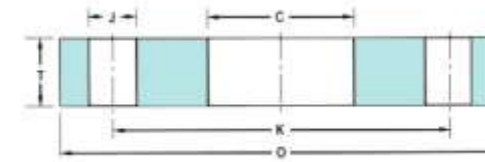

JIS 16 K PLFF (16kg/cm ²)									
NOMINAL PIPE SIZE		OUTER DIAMETER O (mm)	INTERNAL DIAMETER C (mm)	THICKNESS T (mm)	NO. OF BOLT HOLES	DIAMETER OF BOLT HOLES J (mm)	DIAMETER OF BOLT HOLE K (mm)	APPROXIMATE WEIGHT (kg)	
mm	Inch							FLAT FACE	BLIND
15	1/2	95	22.2	12	4	15	70	0.57	
20	3/4	100	27.7	14	4	15	75	0.73	
25	1	125	34.5	14	4	19	90	1.13	
32	1 1/4	135	43.2	16	4	19	100	1.48	
40	1 1/2	140	49.1	16	4	19	105	1.56	
50	2	155	61.1	16	8	19	120	1.88	
65	2 1/2	175	77.1	18	8	19	140	2.60	
80	3	200	90.0	20	8	23	160	3.41	
100	4	225	115.4	22	8	23	185	4.40	
125	5	270	141.2	22	8	25	225	6.51	
150	6	305	166.6	24	12	25	260	8.55	
200	8	350	218.0	26	12	25	305	10.82	
250	10	430	269.5	28	12	27	380	17.88	
300	12	480	321.0	30	16	27	460	21.42	
350	14	540	358.1	34	16	33	480	30.62	
400	16	605	409.0	38	16	33	540	42.51	
450	18	675	460.0	40	20	33	605	54.85	
500	20	730	511.0	42	20	33	660	64.78	
600	24	845	613.0	46	24	39	770	85.64	

[TECHNICAL DATA]

MILD STEEL PLATE FLANGE JIS

JIS 5K PLFF(5kg/cm ²)									
NOMINAL PIPE SIZE		OUTER DIAMETER O (mm)	INTERNAL DIAMETER C (mm)	THICKNESS T (mm)	NO. OF BOLT HOLES	DIAMETER OF BOLT HOLES J (mm)	DIAMETER OF BOLT HOLE K (mm)	APPROXIMATE WEIGHT (kg)	
mm	Inch							FLAT FACE	
15	1/2	80	22.2	9	4	12	60	0.30	
20	3/4	85	27.7	10	4	12	65	0.37	
25	1	95	34.5	10	4	12	75	0.45	
32	1 1/4	115	43.2	12	4	15	90	0.78	
40	1 1/2	120	49.1	12	4	15	95	0.85	
50	2	130	61.1	14	4	15	105	1.07	
65	2 1/2	155	77.1	14	4	15	130	1.49	
80	3	180	90.0	14	4	19	145	1.99	
100	4	200	115.4	16	8	19	165	2.39	
125	5	235	141.2	16	8	19	200	3.23	
150	6	265	166.8	18	8	19	230	4.41	
200	8	320	218.0	20	8	23	280	6.25	
250	10	385	269.5	22	12	23	345.0	9.40	
300	12	430	321.0	22	12	23	390	10.25	
350	14	480	358.1	24	12	25	435	14.0	
400	16	540	409.0	24	16	25	495	16.92	
450	18	605	460.0	24	16	25	555	21.37	
500	20	655	511.0	24	20	25	605.0	23.1	
600	24	770	613.0	26	20	27	715	32.5	

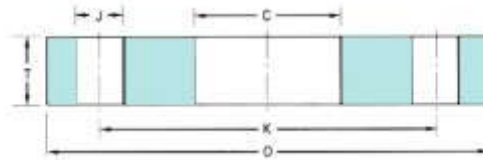

JIS 10K PLFF(10kg/cm ²)									
NOMINAL PIPE SIZE		OUTER DIAMETER O (mm)	INTERNAL DIAMETER C (mm)	THICKNESS T (mm)	NO. OF BOLT HOLES	DIAMETER OF BOLT HOLES J (mm)	DIAMETER OF BOLT HOLE K (mm)	APPROXIMATE WEIGHT (kg)	
mm	Inch							FLAT FACE	
15	1/2	95	22.2	12	4	15	70	0.57	0.81
20	3/4	100	27.7	14	4	15	75	0.73	0.79
25	1	125	34.5	14	4	19	90	1.13	1.24
32	1 1/4	135	43.2	16	4	19	100	1.48	1.66
40	1 1/2	140	49.1	16	4	19	105	1.56	1.81
50	2	155	61.1	16	4	19	120	1.88	2.23
65	2 1/2	175	77.1	18	4	19	140	2.60	3.296
80	3	185	90.0	18	8	19	150	2.81	3.54
100	4	210	115.4	18	8	19	175	3.10	4.66
125	5	250	141.2	20	8	23	210	4.77	7.30
150	6	280	166.8	22	8	23	240	6.34	10.1
200	8	330	218.0	22	12	23	290	7.50	14.1
250	10	400	269.5	24	12	25	355	11.80	22.7
300	12	445	321.0	24	16	25	400	12.58	27.82
350	14	490	358.1	26	16	25	445	16.33	38.2
400	16	560	409.0	28	16	27	510	23.24	52.13
450	18	620	460.0	30	20	27	565	29.26	68.4
500	20	675	511.0	30	20	27	620	33.28	81.58
600	24	795	613.0	32	24	33	730	45.40	120

CANGZHOU HUAYE

METAL PRODUCTS CO., LTD.

FORGED FLANGE ASTM A105 ANSI B16.9

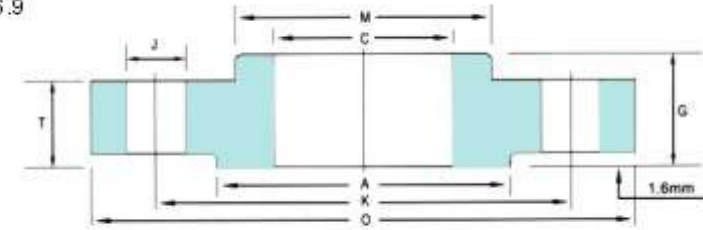

150LB SORF												
NOMINAL PIPE SIZE		OUTER DIA. O (mm)	OUTER DIA. C (mm)	THICK- NESS T (mm)	TOTAL THICK- NESS G (mm)	DIA. OF HUB at BASE M (mm)	DIA. OF RAISED FACE A (mm)	NO. OF BOLT HOLES	NO. OF BOLT HOLES J (mm)	DIA. OF BOLT CIRCLE K (mm)	APPROXIMATE WEIGHT (kg)	
mm	Inch										SO RF	BLIND
15	1/2	89	22.3	11.1	16	30.2	34.9	4	15.9	60.3	0.5	0.5
20	3/4	98	27.7	12.7	16	38.1	42.9	4	15.9	69.9	0.9	0.9
25	1	108	34.5	14.3	17	49.2	50.8	4	15.9	79.4	0.9	0.9
32	1 1/4	117	43.2	15.9	21	57.7	63.5	4	15.9	88.9	1.4	1.4
40	1 1/2	127	49.5	17.5	22	65.1	73.0	4	15.9	98.4	1.4	1.80
50	2	152	62.0	19.1	25	77.6	92.1	44	19.1	120.7	2.3	2.3
65	2 1/2	178	74.7	22.2	29	90.5	104.8	4	19.1	139.7	3.2	3.2
80	3	191	90.7	23.8	30	107.9	127.0	4	19.1	152.4	3.6	4.10
100	4	229	116.1	23.8	33	134.9	157.2	8	19.1	190.5	5.9	7.70
125	5	254	143.8	23.8	37	163.5	185.7	8	22.2	215.9	6.8	9.1
150	6	279	170.7	25.4	40	192.1	215.9	8	22.2	241.3	8.6	11.8
200	8	343	221.5	28.6	44	246.1	269.9	8	22.2	298.5	13.6	20.4
250	10	406	276.3	30.2	49	304.8	323.8	12	25.4	362.0	19.5	31.8
300	12	483	327.1	31.8	56	365.1	381.0	12	25.4	431.8	29.0	49.9
350	14	533	359.2	34.9	57	400.0	412.8	12	28.6	476.3	41	63.5
400	16	597	410.5	36.5	64	457.2	469.9	16	28.6	539.8	44.5	81.6
450	18	635	461.8	39.7	68	504.8	533.4	16	31.8	577.9	59.0	99.8
500	20	699	513.1	42.9	73	558.8	584.2	20	31.8	635.0	75.0	129
600	24	813	615.9	47.6	83	663.6	692.2	20	34.9	749.3	99.8	195

NOMINAL SIZE DN	SOCKET		HALF SOCKET	
	MINIMUM OUTSIDE DIA. A (mm)	OVERALL LENGTH B (mm)	MINIMUM OUTSIDE DIA. C (mm)	OVERALL LENGTH D (mm)
6	15.0	17	15.0	8
8	18.5	25	18.5	11
10	21.3	26	21.3	12
15	26.6	34	26.6	16
20	31.8	38	31.8	17
25	38.5	43	39.5	20
32	48.3	48	48.3	22
40	54.5	48	54.5	22
50	66.2	55	68.0	26
65	82.0	65	84.2	30
80	95	71	98.4	34
100	121.4	83	124.0	40
125	146.3	92	149.0	44
150	173.3	92	177.0	44

